

**E-TENDER DOCUMENT FOR SUPPLY AND INSTLALATION
OF PUSH BACK CHAIRS IN MAIN AND MINI AUDIOTORIUM
AT SCIENCE CITY, KOLKATA**



विज्ञान नगरी

(राष्ट्रीय विज्ञान संग्रहालय परिषद)

संस्कृति मंत्रालय, भारत सरकार

जे. बी.एस. हलडेन एवेन्यु, कोलकाता - 700046



Science City

(National Council of Science Museums)
Ministry of Culture, Government of
India

**J B S Haldane Avenue, Kolkata
700046**

E-ENDER NO: SCCY-15014/30(408)/2019

**INSTRUCTIONS TO THE TENDERERS/BIDDERS FOR E-SUBMISSION OF BIDS ONLINE
THROUGH E-PROCUREMENT SITE <https://eprocure.gov.in/eprocure/app>**

This tender document has been published on the Central Public Procurement (CPP) Portal (URL: <https://eprocure.gov.in/eprocure/app>). The tenderers /bidders are required to submit soft copies of their bids electronically on the CPP Portal, using valid Digital Signature Certificates (DSC). The instructions given below are meant to assist the tenderers/bidders in registering on the CPP Portal, prepare their bids in accordance with the requirements and submitting their bids online on the CPP Portal. More information useful for submitting online bids on the CPP Portal may be obtained at: <https://eprocure.gov.in/eprocure/app>

REGISTRATION:-

- 1) Tenderers/bidders are required to enrol on the e-Procurement module of the Central Public Procurement Portal (URL: <https://eprocure.gov.in/eprocure/app>) by clicking on the link **“Click here to Enrol”** on the CPP Portal. Enrolment is free of Charge. As part of the enrolment process, the tenderers/bidders will be required to choose a unique username and assign a password for their accounts. Tenderers/bidders are advised to register their valid email address and mobile numbers as part of the registration process. These would be used for any communication from the CPP Portal. Upon enrolment, the tenderers/bidders will be required to register their valid Digital Signature Certificate (Class II or Class III Certificates with signing key usage) issued by any Certifying Authority recognized by CCA India (e.g. Sify/ TCS/nCode / eMudhra etc.), with their profile. Only one valid DSC should be registered by tenderers/bidders. Please note that the tenderers/bidders are responsible to ensure that they do not lend their DSC’s to others which may lead to misuse. Bidder then logs in to the site through the secured log-in by entering their user ID & password and the password of the DSC / e-Token.

SEARCHING FOR TENDER DOCUMENTS:-

- (a) There are various search options built in the CPP Portal, to facilitate tenderers/bidders to search active tenders by several parameters. These parameters could include organization name, location, date, value, etc. There is also an option of **‘Advanced Search’** for tenders, wherein the tenderers/bidders may combine a number of search parameters such as organization name, form of contract, location, date, other keywords etc. to search for a tender published on the CPP Portal.
- (b) Once the tenderers/bidders have selected the tenders they are interested in, they may download the required documents / tender schedules. These tenders can be moved to the respective “My Tenders” folder. This would enable the CPP Portal to intimate the tenderers/bidders through SMS/e-mail in case there is any corrigendum issued to the tender document.
- (c) The bidder should make a note of the unique Tender ID assigned to each tender, in case they want to obtain any clarification / help from the Helpdesk.

PREPARATION OF BIDS:-

- (a) Tenderer/bidder should take into account any corrigendum published on the tender document before submitting their bids. Please go through the tender advertisement and the tender document carefully to understand the documents required to be submitted as part of the bid. Please note the number of covers in which the bid documents have to be submitted, the number of documents - including the names and contents of each of the document that need to be submitted.
- (b) Bidder, in advance, should get ready the bid documents to be submitted as indicated in the tender document / schedule and generally they can be in PDF / XLS / RAR / DWF formats as mentioned. **Bid documents may be scanned with 100 dpi with black and white option.**

- (c) To avoid the time and efforts required in uploading the same set of standard documents which are required to be submitted as a part of every bid, a provision of uploading such standard documents (e.g. PAN card copy, annual reports, auditor certificates etc.) has been provided to the tenderers/bidders. Tenderers/bidders can use “My Space” area available to them to upload such documents. These documents may be directly submitted from the “My Space” area while submitting the bid just by tagging and need not be uploaded again and again. This will lead to a reduction in the time required for bid submission process.

SUBMISSION OF BIDS:-

- 1) Tenderer/bidder should log into the site well in advance for bid submission so that he/she uploads the Bid in time i.e. on or before the bid submission time as per the system. Bidder will be responsible for any delay due to other issues.
- 2) Tenderer/bidder has to digitally sign and upload the required bid documents one by one as indicated in the tender document.
- 3) Tenderer/bidder has to select the payment option as “offline” to pay the Tender Fee & EMD and enter details of DD/any other accepted instrument.
- 4) Tenderer/bidder should prepare the Tender Fee & EMD instrument as per the instructions specified in the tender document. Scanned copy of DD/any other acceptable instrument as mentioned towards EMD & Tender Fee should be uploaded while online submission of the tender and the original should be posted/ couriered/ given in person to the Tender Processing Section latest by the last date and time of bid submission or as specified in the tender documents. The details of the DD/any other accepted instrument, physically sent, should tally with the details available in the Scanned copy and the data entered during bid submission time otherwise the Tender will be summarily rejected.
- 5) The Tender Inviting Authority (TIA) will not be held responsible for any sort of delay or the difficulties faced during the submission of bids online by the tenderers/bidders. The bidder should see that the bid documents submitted should be free from virus and if the documents could not be opened, due to virus, during tender opening, the bid is liable to be rejected.
- 6) Tenderers/bidders are requested to note that they should necessarily submit their financial bids in the format provided and no other format is acceptable. The price bid has been given as a standard **Offer Sheet** in .xls format with the tender document, which is to be downloaded and to be filled by all the tenderers/bidders. Tenderers/bidders are required to download the **Offer Sheet** file, open it and complete the **green coloured (unprotected)** cells with their respective financial quotes and other details (such as name of the Tenderer/bidder). No other cells should be changed. Once the details have been completed, the tenderer/bidder should save it and submit it online, without changing the filename. If the **Rate Quote Sheet** file is found to be modified by the tenderer/bidder, the bid will be rejected. In e-Tendering, intending tenderer/bidder can quote their rate in figures only. The total amount is generated automatically. Therefore, the rate quoted by the tenderer/bidder in figures shall be taken as correct. The Comparative Statement is also generated automatically by the system. The Comparative Statement and rate quoted by each tenderer/bidder shall be downloaded.
The manual calculation check of tenders/bids and Comparative Statement, shall be final. In case, any discrepancy is noticed, the decision of appropriate authority of museum/centre shall be final and binding.
- 7) The server time (which is displayed on the tender’s/bidder’s dashboard) will be considered as the standard time for referring the deadlines for submission of the bids by the tenderers/bidders, opening of bids etc. The tenderers/bidders should follow this time during bid submission. The tenderers/bidders are requested to submit the tenders/bids through online e-tendering system to the **Tender Inviting Authority (TIA)** well before the bid submission end date & time (as per Server System Clock).

- 8) All the documents being submitted by the tenderers/bidders would be encrypted using PKI encryption techniques to ensure the secrecy of the data. The data entered cannot be viewed by unauthorized persons until the time of bid opening. The confidentiality of the bids is maintained using the secured Socket Layer 128 bit encryption technology. Data storage encryption of sensitive fields is done.
- 9) The uploaded tender documents become readable only after the tender opening by the authorized tender/bid openers.
- 10) Upon the successful and timely submission of tenders/bids, the portal will give a successful tender/bid submission message & a tender/bid summary will be displayed with the NIT/tender/bid no. or Name of Work and the date & time of submission of the tender/bid with all other relevant details.
- 11) The tender/bid summary has to be printed and kept as an acknowledgement of the submission of the bid. This acknowledgement may be used as an entry pass for any tender/bid opening meetings.

ASSISTANCE TO TENDERERS/BIDDERS:-

- (a) Any queries relating to the tender document and the terms and conditions contained therein should be addressed to the
**Tender Inviting Authority (TIA),
Science City, J.B.S Haldane Avenue, Kolkata-700046,
Fax No.033-22859895,
Website: www.sciencecitykolkata.org,
Email: sciencecity.kol@gmail.com/sctyncsm1@gmail.com)**
- (b) Any queries relating to the process of online bid submission or queries relating to CPP Portal in general may be directed to the 24x7 CPP Portal Helpdesk Ph. **1800-3070-2232.**

NOTICE INVITING e-TENDER (e-NIT)

No.SCCY-15014/30(408)/2019

Dated 04.06.2019

Science City, Kolkata is a constituent unit of the National Council of Science Museums, Kolkata* (*hereinafter referred to as the Science City).

General terms & Conditions:-

1. Online e-tenders (percentage rate bid) are hereby invited from reputed and experienced agencies for **“Supply and Installation of Push Back chairs in Main and Mini Auditorium at Science City, Kolkata at Science City, J.B.S. Haldane Avenue, Kolkata-700046”** with excellent finishing quality and having the following eligibility:-
 - (i) Should be either registered as a Company under Companies Act 1956/2013 or as a Partnership (including Limited Liability Partnership) under Partnership Act, 1932 as the case may be and should be in existence as such entity for not less than five years as on 30.03.2019. Should be in possession of **(a)** Trade License **(b)** PAN Card [in the name of firm/agency or proprietor]: **(c)** Registration under the Shops & Establishment Act **(d)** GST Registration. The Registered Office or one of the Branch Offices of the tenderer should be located in and around Kolkata. The agency or any of its Partners/Directors etc should not have been black listed/debarred by any of the government agencies or department or should not have been found guilty of commission of acts of moral turpitude or convicted for any economic offence or for violation of any labour laws etc. by any court or any authority appointed to enforce any labour laws or regulations including EPF/ESI authorities. Further no past contract of such agency should have been terminated in the past 3 years on account of violation of laws or deficiency of services or breach of contract **(To be submitted in bidder’s/tenderer’s letterhead as per Annexure - II)**.
 - (ii) Minimum 05 (Five) years experience in executing similar kind of works in Central Government/ Central Autonomous Bodies/ State Govt/ Central Public Sector Undertakings/ Large Corporate Bodies . Tenderer shall attach list of such organizations with contact nos. where the Agency is currently providing/ has earlier provided this kind of service and copies of work order/completion certificate shall be submitted in support of their claim **(To be submitted in bidder’s/tenderer’s letterhead as per Annexure - III)**.
 - (iii) The Tenderer should meet **any one of the three criteria** as under:
 - a. **3 (three)** similar completed work of Supply and Installation of Push Back chairs (at least one of them in any Central Government/ Central Autonomous Bodies/ State Government/ Central Public Sector Undertakings /Reputed Corporate Bodies) each costing not less than **40%** of the estimated cost.

OR
 - b. **2 (two)** similar completed work of Supply and Installation of Push Back chairs (at least one of them in any Central Government/ Central Autonomous Bodies/ State Government/ Central Public Sector Undertakings /Reputed Corporate Bodies) each costing not less than **60%** of the estimated cost.

OR
 - c. **1 (one)** similar completed work of Supply and Installation of Push Back chairs (at least one of them in any Central Government/ Central Autonomous Bodies/ State Government/ Central Public Sector Undertakings /Reputed Corporate Bodies) of aggregate cost not less than **80%** of the estimated cost.

2. The place of work shall be Science City, J.B.S Haldane venue located at Kolkata-700046.

3. Important information & dates

Estimated Cost of Work	₹ 66,78,000/-
EMD Amount	₹ 1,67,000/-
Cost of tender document	₹ NIL
Period of Completion	60 days
Bid Document Publishing Date & Time	04.06.2019 at 18.00 Hrs.
Bid Document Download Start Date & Time	04.06.2019 at 18.00 Hrs.
Bid Document Download End Date & Time	25.06.2018 at 18.00 Hrs.
Bid submission Start Date & Time	04.06.2019 at 18.00 Hrs.
Pre Bid meeting Date & Time	17.06.2019 at 11.30 Hrs
Bid submission End Date & Time	25.06.2018 at 18.00 Hrs.
Bid Opening (Technical) Date & Time	27.06.2018 at 15.00 Hrs.

4. The intending tenderers/bidders must read the terms and conditions of the contract carefully. They should submit their bid only if they consider themselves eligible as per the laid down criteria and if they are in possession of all the documents/registrations required.
5. Information and Instructions for tenderers/bidders posted on website shall form a part of the bid document.
6. The bid document consisting of guidelines for **Supply and Installation of Push Back chairs in the Main and Mini Auditorium at Science City, Kolkata at Science City, J.B.S. Haldane Avenue, Kolkata-700046**, job requirement to be fulfilled and the set of Terms and Conditions of the contract to be complied with and other necessary documents can be seen and downloaded free of cost from <https://eprocure.gov.in/eprocure/app>.
7. Out of the online bid documents submitted by intending tenderers/bidders, the technical bids of only those tenderers/bidders shall be opened, who have deposited Earnest Money Deposit as specified above duly scanned, uploaded and found in order. The financial bids of only those tenderers/bidders whose Technical Bids found to be in order and accepted shall be opened by the Tender Evaluation Committee (TEC) authorised for the purpose.
8. Those agencies not registered on the website mentioned above, are required to get themselves registered beforehand.
9. The intending tenderer/bidder must have valid Class II or Class III Certificates with signing key usage (DSC) to submit the bid.
10. The e-Tenders are invited under two envelopes system. The first electronic envelope will be named as **Technical Bid Envelope** & will contain documents of tenderer's/bidder's satisfying the eligibility conditions, scanned copies of Demand Draft towards EMD for the work of **Supply and Installation of Push Back chairs in the Main and Mini Auditorium at Science City, Kolkata at Science City, J.B.S. Haldane Avenue, Kolkata-700046** and the second electronic envelope will be named as **Financial Bid Envelope** containing Rate Quote Sheet. The bidder shall submit **TECHNICAL BID ENVELOPE** and **FINANCIAL BID ENVELOPE** simultaneously. The technical bids will be evaluated first and there after financial bids of only the eligible tenderers/bidders shall be opened. These envelopes shall contain one set of the following documents:-

a) TECHNICAL BID ENVELOPE shall contain the following documents:

- (i) Scanned copy of Demand Draft/Pay order or Banker's Cheque for ₹1,67,000/- of any Nationalised/ Scheduled Bank in favour of **Science City** payable at **Kolkata** towards **Earnest Money Deposit (EMD)** in .pdf format.
(Physical Demand Draft at Sl. (i) should be submitted to Science City and hard copy of complete Notice Inviting E-Tender endorsing signature and rubber seal of the agency on all the pages on or before 26.06.2019)
- (ii) Scanned copy of Enlistment Order/Registration certificate with appropriate Authority/necessary license as required under the contract labour (Regulation & abolition) Act 1970 or any other act as applicable in .pdf format.
- (iii) Scanned copies of documents towards proof of eligibility as per Clause No.1 (i, ii, & iii) and details of agency as per **Annexure-V** for "**Supply and Installation of Push Back chairs in the main and mini auditorium at Science City, Kolkata at Science City, J.B.S. Haldane Avenue, Kolkata-700046**" EXPERIENCE CERTIFICATES/ CONTRACT EXECUTION CERTIFICATE along with **Work Order** issued by Govt./ Semi-Govt./ Autonomous/ PSUs and Large Corporate Bodies with appropriate Authority as per the NIT in PDF format as per **Annexure -III**.
- (iv) Scanned copy of undertaking as per **Annexure-I** and **Annexure -II** duly signed with agency seal in PDF format.
- (v) **Scanned copies of PAN Card, GSTIN Certificate, and Income Tax Returns for last three years and Trade License in PDF format..**
- (vi) E-tender Document (**NIT**) comprising of Schedule of Quantities/Specification and drawings in PDF format (TENDERXXXXX.pdf file) digitally signed

b) FINANCIAL BID ENVELOPE shall contain:

- i) Rate Quote Sheet (Percentage BOQ Template) in .XLS format. Bidder shall quote percentage rate in this Envelope.
- ii) Bidder must submit buy-back cost (in INR) for existing push back chairs as per **Annexure - IV** in .pdf format. The buyback cost quoted by the bidder may or may not be considered while deciding the lowest bid.

11. E-tenders which do not fulfil any of the above conditions or are incomplete in any respect are liable for **summary rejection**.
12. The Science City does not bind itself to accept the lowest e-tender/bid and has the right to reject or accept any or all the e-tenders/bids; received without assigning any reason whatsoever.
13. Canvassing in connection with e-tenders/bids is strictly prohibited and the e-tenders/bids submitted by the tenderers/bidders that resort to canvassing will be liable for rejection on that ground alone.
- 14. E-tenders, incorporating additional conditions or with deviations from the conditions of contract, the bid not meeting any other requirements stipulated in the e-tender are liable to be rejected.**
15. The tenderer(s) **must declare** in writing that neither he nor any of their Directors/ Partners are in anyway related to any officer in the National Council of Science Museums, Kolkata, or any of its constituent units as per the format given in **Annexure- I**.
16. GST to be paid extra by Science City on submission of proper documentary evidence. However rate of GST as per HSN code may please be mentioned in the tender.
17. Before submitting the e-tender, the tenderer shall assess the quantum of subject services involved after going through the scope of job requirement, Bill of quantities as per annexure to the e-NIT and conditions of contract and inspect the site, if necessary. No claims for additional payments would be entertained arising out of contractor's ignorance of site conditions.

18. For the purpose of opening of the e-tenders/bids as described in Clause 10 of the Notice Inviting e-tender, it is clarified that only on receiving the **EMD physically in Science City, Kolkata together with duly signed and stamped copy of the e-tender document** before the bid opening date, the **Technical Bid Envelope** will be opened. After the authority of Science City is satisfied that the documents in the Technical Bid Envelope are in order, the **FINANCIAL BID ENVELOPE** shall be opened, subsequently by the duly constituted Technical Evaluation committee of the Science City. The date, time and venue of opening of Financial Bids shall be published on the CPP portal later.
19. It may be noted that the Technical Bid Envelope which are not found in order as per the requirement of Science City, Kolkata shall be summarily rejected and the decision of Science City shall be final and binding.
20. Earnest Money is liable to be forfeited if the successful e-tenderer/bidder selected for **Supply and Installation of Push Back chairs in the main and mini auditorium at Science City, Kolkata at Science City, J.B.S. Haldane Avenue, Kolkata-700046** fails to take up the work and sign the formal agreement within 07 days from the date of issue of Letter of Award of License to them by the Science City.
21. The successful tenderer will be awarded the services of **Supply and Installation of Push Back chairs in the main and mini auditorium at Science City, Kolkata at Science City, J.B.S. Haldane Avenue, Kolkata-700046** by the Science City and given stipulated time which shall be counted from the date of issue of the LOI. During this intervening period, the successful tenderer shall check the job requirement, specification, drawings and BOQ. The successful tenderer shall also mobilise all its resources and sign an Agreement with Science City in approved format on a non-judicial stamp paper of appropriate value.
22. All credential of the agency including financial standing, registration with Govt. Having support or connection with Govt. Dept./ Organisation, Semi Govt., Autonomous Body, Public Body, Local Govt. Civil Body and Public Institution/ Organization and Large Corporate Bodies.

=0=0=0=

APPENDIX TO NIT

1. SUMMARY OF CONDITIONS OF CONTRACT

- a) Defect Liability Period : One year from the date of completion as certified by the Museum.
- b) Time for Completion : 60 (Sixty) days
- c) Minimum value of work for Interim Certificate : 5% of the estimated value or less at the discretion of the Science City, but more than one running bill in a month.
- d) Earnest Money to be deposited with the e-tender. : ₹ 1,67,000/-
- e) Liquidated damages for non completion of work in time (Clause 19 of the general conditions of contract). : One percent per week of the total cost of the work awarded subject to a maximum of 10% of gross value of work done or cost of the work awarded whichever is greater
- f) Liquidated damages for insufficient progress of work (Clause 19 of the general conditions of Contract). : Half percent per week of the total cost of the work awarded subject to a maximum of 10% of gross value of work done or cost of the work awarded whichever is greater.

2. RETENTION MONEY FOR INTERIM PAYMENT

- a) EMD : 2.5 % of the estimated value to be deposited with e-tender.
- b) Retention Money: : 10% of the value of the work including Earnest Money.
- c) Period of submitting final bill by the successful e-tenderer : Three months from the date of virtual completion.

FORMAT FOR LETTER OF INTENT

Ref. No.(Mention file number)

Date.....

Sub: Letter of Intent for the work of Supply and installation of Push Back Chairs in Main and Mini Auditorium in Science City, Kolkata

Dear Sirs,

With reference to your e-tender dated(and further clarification vide letter number dated), it is intended to award the aforesaid work at the e-tendered amount of Rs..... (Value based on only items of work intended to be awarded for execution).

You are, therefore, requested to sign an agreement as per standard format already printed in the e-tender documents purchased by you while e-tendering for this job. For this purpose, you are requested to send us a non-judicial stamp paper of appropriate value for preparing the contract Agreement within a week from the date of this letter.

You may avail of 07days mobilization time from the date of issue of this letter of Intent for mobilizing your men, materials and other necessary resources for the construction. During mobilization period, you are requested to study all the drawings and designs annexed hereto and obtain clarifications from the architect or this office immediately. Please note that the work has to be completed within 60 (Sixty) days in which mobilization time period of 07 days is also included.

The date of commencement of work would be reckoned as the date of issue of this letter.

Thanking you,

Yours faithfully,

Sd/-

Controller of Administration

GENERAL CONDITIONS OF THE CONTRACT

1. In consideration of payments to be made to him as hereinafter provided the Successful e-tenderer shall upon and subject to the conditions herein contained execute and complete the work of Supply and Installation of Push Back Chairs in the Main and Mini Auditorium at Science City, JBS Haldane Avenue, Kolkata - 700046 within Sixty (60) days from the date of issue of the work order (as per clause 1 of the e-NIT) and such further details furnished to him from time to time and described in the said specifications and the said priced schedule of quantities along with the progress of the work.
2. The Science City shall pay to the Agency such sum as shall become payable hereunder at the time and in the manner specified in the said terms and conditions of the e-NIT.
3. Time is the essence of this agreement and the Agency shall proceed with the work, throughout the stipulated period of this contract. At any stage during execution, if the work lags behind the schedule for reasons directly attributable to the agency, he shall pay or allow the Museum / Centre to deduct from any money due to him as liquidated damage as per the conditions of contract.
4. The rates quoted in the offer shall be inclusive of removing and stacking of existing chairs carefully, cost of materials required for supply and installation, labour & supervision charges, all working accessories. The rate of GST and Labour Welfare Cess shall be payable extra as per actual and upon submission of proper evidence. Rate quoted shall be firm and fixed for entire period of execution of the job and no escalation of rate on any ground whatsoever shall be applicable/allowed.
5. Every effort should be made to complete the work/job by the Agency within the stipulated time schedule. In case of the agency fails to comply within the specified time schedule as per the finalized and accepted terms and conditions, Science City, authority in addition to impose the penalty may either cancel the order and get the unfinished work completed at the risk and cost of the Successful e-tenderer. The decision of the Science City shall be final and binding on the Agency.
6. The Agency also mandatorily arrange inspection of the item/job and the final job whenever desired by the authorized officer of Science City. Any/ all defect pointed out by the competent representative of Science City during such inspection have to be promptly rectified at the cost (including material cost) to meet the desired quality and specification as per requirement failing which penal action shall be taken as will deem fit by the authority of Science City in this regard shall be final and binding on the Successful tenderer.
7. The defect liability period shall be 12 months from the date of completion of the work. During the period, the Agency shall rectify the defective items within a reasonable time up to the satisfaction of the Competent Authority of Science City or otherwise Science City shall have the right to rectify the defect at the Successful e-tenderer's risk and cost of which will be deducted from the Security Deposit or any other payment due to the Agency.
8. Bad workmanship will not be accepted and if carried out is liable to be rejected and should be rectified by the Agency at his cost as per specifications and directions given by the authorized representative of Science City. Decision of Science City as

to items of bad workmanship and proper replacement/rectification will be final and binding to the Agency.

9. Specifications of the items are as given in the tender. However, if any ambiguity in the specification is detected it shall be promptly brought to the notice of Science City for clarification. No deviation from the approved specifications shall be made by the Agency without written approval of the authority of Science City.
10. In case the Agency refuses to accept the offer after finalization or does not comply within 7 days from the date of placement of the order as per the finalized and accepted terms and conditions the order shall be cancelled forthwith without any further reference and the EMD will be forfeited.
11. The authority of Science City reserves the right to amend, alter or modify the terms and Conditions or quantities mentioned above and can slit the order with different parties if necessary.
12. The authorities of Science City does not bid themselves to accept the lowest tender and reserves the right to reject or accept any or all tenders wholly or partially without assigning any reason whatsoever.
13. The Agency shall obtain necessary trade and other license/ permission as maybe required to carry out the order job at Science City, Kolkata and shall also be responsible for compliance of all statutory rules and regulations which maybe in force time to time from the appropriate authorities at their own.
14. The Agency shall not under any circumstances whatsoever transfer wholly or partially this contract/ agreement to any other person(s)/firm/company or assign the contract/agreement benefit of this contract/agreement to any other arty for any reason whatsoever, otherwise the contract/agreement stand cancelled.
15. The chairs are to be fixed in carpeted area and tiled area. The Agency has to take sufficient care not to damage or make the carpet dirty. The Agency will make good to the loss in case of any damage.
16. The Agency shall fabricate and supply sample chair of the ordered specification and get the approval of the competent authority of Science City before final fabrication of chair for which no separate time shall be allowed.
17. At any stage during the execution of the work if the work lags behind the for reasons directly attributable to the Agency, he shall be liable to pay as agreed liquidated damages equivalent to half percent of the total cost of work awarded every week for the period the work lags behind subject to a maximum of 10% of the total value of work, awarded or gross value of work done, whichever is greater.
18. In the event of Agency's inability to complete the construction work by the scheduled date of completion, the Science City shall have the right to terminate the contract as per Clause 8 or allow the Agency to continue and complete the work within specific date. In the latter case, during the period of continuation, the Agency shall pay as agreed liquidated damage equivalent to one per cent of the total cost of work awarded for every week that the work remains unfinished subject to a maximum of 10% of the total value of work awarded or gross value of work done, whichever is greater.

19. The Agency shall pay a sum equivalent to 10% of the total cost of the work awarded towards Security Deposit in the form of Bank Draft before the commencement of the work.
20. All disputes and differences between the Agency and Science City, of any kind whatever arising out of or in connection with the order on the carrying out the work of Supply and installation of push back chairs at the Main and Mini Auditorium in Science City, Kolkata (whether during the progress of the work or after their completion and whether before breach of the terms & conditions of the order) shall be referred to the sole arbitration of a person to be nominated by the Director General, National Council of Science Museums, on receipt of an official request with details of dispute from either Science City or the Agency. The award of the arbitrator so appointed shall be final, conclusive and binding on all parties to the contract. The submission shall be deemed to be submission to arbitration under the Arbitration and Reconciliation Act, 1996 or any statutory modification or re-enactment thereof and of the rules made there under for the time being in force.
21. In case of any legal dispute, other than the arbitration, the Court of Jurisdiction shall be at the place of written in the first line of this agreement.

(Format for Declarations & Undertaking to be typed on bidder agency's letterhead and to be submitted in Part -I (TECHNICAL ENVELOPE) of the e-tender document)

DECLARATION -1

This is to certify that neither we/any of us/ are/is in anyway related to any employee in the National Council of Science Museums, Kolkata, or any of its constituent units.

Date:
Place:

**(Signature of the tenderer
with agency seal/rubber stamp)**

DECLARATION -2

We hereby declare that we have not quoted any extra condition along with the Part-II (FINANCIAL ENVELOPE) of the e-tender.

Date:
Place:

**(Signature of the tenderer
with agency seal/rubber stamp)**

UNDERTAKING

This is to certify that we have carefully gone through the job requirement, terms and conditions given in the e-tender document & have clearly understood the terms & conditions of the tender and have accordingly quoted our balanced rates in conformity to minimum wages and statutory payments, after going through all the details as per Annexure – V of E-NIT.

Further, we hereby declare that we have thoroughly inspected the premises of Science City, Kolkata and also studied the departmental estimate for providing the *work of Supply and installation of push back chairs in Main and Min Auditorium at Science City, J.B.S. Haldane Avenue, Kolkata-700046* including the list of materials required for providing the services as enumerated in the E-NIT and submitting our rate quote sheet (Offer) considering these elements of the E-NIT.

We hereby give an undertaking that we shall provide the "*Supply and installation of push back chairs in the Main and Mini Auditorium at Science City, J.B.S. Haldane Avenue, Kolkata-700046*" strictly as per the given job requirement during the period of contract.

We also undertake that the physical **EMD** instrument shall be deposited by us with the office of **Science City, payable at Kolkata** before the bid opening date. Otherwise the **Science City** shall reject the bid and debar us from further tendering in NCSM or its constituent units.

Date:
Place:

**(Signature of the tenderer
with agency seal/rubber stamp)**

Certified that the agency or any of its partners/Director have not been blacklisted/debarred by any of the Govt. agencies or department or have not been found guilty of commission of acts of moral turpitude or convicted for any economic offence or violation of any labour laws etc. by any Court or any PF/ESI authorities.

It is further certified that the agency has not been terminated by any of the Govt. department/autonomous institutions/public sector undertaking of the Govt. of India/other State Govt. or Public sector Bank or local bodies/Municipalities/ Large Corporate Bodies during past three years on violation of loss or deficiency of service or breach of contract.

Date:
Place:

(Signature of the tenderer
With agency seal /rubber stamp)

Annexure - III

Certified that the agency has undertaken the services of similar jobs of Supply and Installation of Push Back chairs at the following Govt. department/autonomous institutions/public sector undertaking of the Govt. of India/other State Govt. or Public sector Bank or local bodies/Municipalities / Large Corporate Bodies during last five years:

Sl. No.	Name of the Office	Details of Service	Duration of contract	Contract Value
a)				
b)				
c)				
d)				
e)				

Date:
Place:

(Signature of the tenderer
With agency seal /rubber stamp)

Sub: Buy back offer for existing Push Back Chairs

Sl. No.	Description	Quantity	Amount (INR)
1	Buy back of existing Push Back Chairs	1060	

Note:

- i) Existing Push Back Chairs mean the chairs which were installed in 1996-97.
- ii) Before quoting, Agency must see and assess the existing push back chairs thoroughly.
- iii) Amount to be quoted (in INR) as per above format and uploaded in financial Bid as a separate envelope in pdf format.
- iv) The buyback cost (in INR) for existing Push Back chairs may or may not be considered while deciding the lowest bid.

Place: _____
Date : _____

Signature with date & seal of the
Proprietor/Partner/Director/C.E.O.

INFORMATION IN RESPECT OF THE BIDDER

(All information should be given in the following format with complete details)

1. Name of the Agency :
2. Permanent address (full) :
3. Telephone/Fax No.
 - a. Office :
 - b. Office hours :
 - c. Mobile No :
 - d. E-Mail ID :
 - e. Website :
4. Date of Establishment: :
5. Type of Agency (proprietorship /Partnership/ Ltd. company /other)(relevant documentary evidence to be attached) :
6. Number of professionally qualified permanent staff employed in the farm in different capacity :
7. Experience in Supply and Installation of Push Back chairs in auditoriums especially in Govt./Semi Govt./Autonomous organizations/ PSUs carried out in last 5 years which can be supplemented with supporting documents (Attach photocopies of work order and completion Certificate and photographs) :
 - a. Client :
 - b. Cost of work :
 - c. Period :
 - d. Capacity of Auditorium/Hall :
 - e. Staff employed :
8. Present assignment if any (Submit supporting documents) :
9. List of Mechanical & Electrical equipment owned by the Agency such as hoists etc. :
10. Will the Agency submit a performance guarantee if required :
Copies of the Income Tax return for the last three years and Balance Sheet of the Firm. :
11. GST Registration No. :
(Attach copy)
12. Income Tax PAN No. :
(Copy of card to be attached)

::2::

13. Please indicate if any Court Case/ Arbitration proceeding is pending against the agency, if so details thereof and the outcome may please be mentioned :
14. Is the Agency having in house facility? If yes then give the details :
- a) Have PU injection/ CNC Cutting/ Laser cutting/ Vacuum forming of plastic/ 7 Tank powder coating/ conveyor assembly/ Robotic welding/ circular grinding saw with wide belt grinding/ standing/ polishing :
 - b) Testing – Having equipment for measuring thickness/ Densities :
 - c) Power coating: to be by hoist and crane system followed by degreasing/ de-rusting/Activation followed by 7 Tank powder coating process.

Certified that the information furnished above are true to the best of my/our knowledge. It is hereby declare that I/we abide by the decision of Museum/Centre for registration and short-listing of agencies for issue of tender paper.

Place: _____
Date : _____

Signature with date & seal of the
Proprietor/Partner/Director/C.E.O.

TENDER ACCEPTANCE LETTER
(To be given on Company Letter Head)

Date: _____

To,
The Director Science City,
JBS Haldane Avenue
Kolkata- 700046

Sub: Acceptance of Terms & Conditions of Tender.

Tender Reference No: SCCY-15014/30(408)
Name of Tender/Work: Supply and Installation of Push Back Chairs for Main and
Mini Auditorium in Science City, JBS Haldane Avenue,
Kolkata

Dear Sir,

I/ We have downloaded/obtained the e-tender document(s) for the above mentioned Tender/Work from the web site(s) namely: _____ as per your advertisement, given in the above mentioned website(s).

I / We hereby certify that I / we have read the entire terms and conditions of the tender documents from Page No. _____ to _____ (including all documents like annexure(s), schedule(s), drawings etc .), which form part of the contract agreement and I / we shall abide hereby by the terms / conditions / clauses contained therein.

The corrigendum(s) issued from time to time by your department/ organisation too has also been taken into consideration, while submitting this acceptance letter.

I / We hereby unconditionally accept the tender conditions of above mentioned tender document(s) / corrigendum(s) in its totality / entirety.

I / We do hereby declare that our Firm has not been blacklisted/ debarred by any Govt. Department/Public sector undertaking.

I / We certify that all information furnished by the our Firm is true & correct and in the event that the information is found to be incorrect/untrue or found violated, then your department/ organisation shall without giving any notice or reason therefore or summarily reject the bid or terminate the contract, without prejudice to any other rights or remedy including the forfeiture of the full said earnest money deposit absolutely.

Yours Faithfully,

(Signature of the Bidder with Official Seal)

FORMAT FOR ARTICLES OF AGREEMENT

ARTICLES OF AGREEMENT made at Science City, Kolkata this day of between Science City, J.B.S Haldane Avenue, Kolkata-700046 unit of National Council of Science Museums, (NCSM), a society registered under the Societies’ Registration Act of West Bengal, 1961, and functioning as an autonomous scientific organization under Ministry of Culture, Govt. of India having its office at Sector-V, Block-GN, Bidhan Nagar, Kolkata-700091 (hereinafter referred to as Science City, which expression shall unless repugnant to the context, mean and include its successors, executors, administrators and assigns) **ON THE ONE PART**

and

M/s.trading in the name and style of (hereinafter referred to as “LICENSEE”, which expression shall, unless it be repugnant to the context, shall mean and include heirs, executors, administrators and assigns) **ON THE OTHER PART.**

WHEREAS the Science City, Kolkata is desirous of getting the work of “Supply and Installation of Push Back chairs at the Main and Mini Auditorium at Science City, Kolkata at Science City, J.B.S. Haldane Avenue, Kolkata-700046” and issued an e-Tender Notice vide No. SCCY-..... and Tender ID:..... with detailed scope of work, quantities & specifications, BOQ/BOM & job requirement, terms & conditions and describing the work required to be executed under the contract which shall be an integral part of this agreement.

AND WHEREAS the financial bid made by the said successful bidder in response to the said e-NIT has been accepted as the most competitive and accordingly award of contract (which forms a part of this agreement) was issued to the successful bidder vide award of contract No:dated awarding the aforesaid work Supply and Installation of Push Back chairs at Science City, Kolkata at Science City, J.B.S. Haldane Avenue, Kolkata-700046 at the tendered value of(Rupees only) inclusive of GST as applicable.

NOW IT IS HEREBY AGREED AND DECLARED BY AND BETWEEN THE PARTIES HERETO AS FOLLOWS:

1. In consideration of the payments to be made to him as hereinafter provided the successful tenderer shall upon and subject to the conditions herein contained shall carry out and execute the Supply and Installation of Push Back chairs at Science City, Kolkata at Science City, J.B.S. Haldane Avenue, Kolkata-700046 and as per the scope of work and terms and conditions of the contract.
2. The Museum/Centre shall pay to the successful tenderer such sum as shall become payable hereunder at the time and in the manner specified in the said conditions.
3. Time is the essence of this agreement and the successful tenderer shall execute the work, throughout the stipulated period of this contract, strictly according to the direction of Officer-in-charge.
4. This e-Notice Inviting Tender (including Appendix), conditions of contract, priced schedule of quantities and specifications shall form the basis of this agreement and the decision of the Science City in reference to all matters or disputes as to material and workmanship shall be final and binding on the agency.

5. In the event of Agency's inability to complete the work by the scheduled date of completion, Science City shall have the right to terminate the contract as per terms and conditions of the contract or allow the Agency to continue and complete the work within specific date. In the later case, during the period of continuation, the Agency shall pay liquidated damage equivalent to half per cent of the total cost of work awarded for every week that the work remains unfinished subject to a maximum of 10% of the total value of work awarded or gross value of work done, whichever is greater.
6. The agency shall pay a sum equivalent to 10% of the total cost of the work awarded towards Security Deposit in the form of Bank Draft or Bank Guarantee before the commencement of the work.
7. All disputes and differences of any kind whatever except as excluded under contract arising out of or in connection with the contract of carrying out of work (whether during the progress of the work or after their completion and whether before or after the determinations, abandonment or breach of the contract) shall be referred to arbitration as per Clause 28 of the said conditions of contract. In case of any legal dispute, other than the arbitration, the court of jurisdiction shall be at the place written in the first line of this agreement.

The provisions of the Arbitration & Conciliation Act 1996 or any statutory modification or re-enactment thereof and of the rules made there under for the time being in force shall apply to arbitration proceedings under this clause.

In witness whereof the parties have set their respective hands the day and the year and the place hereinabove written.

Signed by for and on behalf of Science City, Kolkata.

In presence of _____

- 1).....
- (2).....

Signed by the said successful tenderer

In presence of _____

- 1).....
- (2).....

Science City, Kolkata
CHECK LIST ON PREPARATION OF BIDS

Sl.No.	Particulars	Yes/No
1.	Have you filled in and signed the Contact Details Form?	
2.	Have you read and understood various conditions of the Contract and shall abide by them?	
TECHNICAL BID		
3.	Have you enclosed the D.D. EMD of Rs. 1,67,000/- in the Technical Bid?	
4.	Have you taken prints of all the Sections of Tender, in the prescribed paper size and signed on all the pages of the tender documents?	
5.	Have you attached with tender the proof of having met the required minimum eligibility criteria?	
6.	Legal Valid Entity: Have you attached the attested Certificate issued by the Registrar of firms/Companies with the tender?	
7.	Financial Capacity: Have you attached Audited Balance Sheets with the tender?	
8.	Registration with Government Bodies like ESIC, EPF, Labour Laws : Have you attached a copy of each of the Registration certificate with the tender?	
9.	Experience: Have you attached the attested experience certificates issued by the Organisations/Government Departments/Corporate Sector for the last five years with the tender?	
10.	Have you attached the copy of work order for the similar work of Supply and Installation of push back chairs during last three years?	
11.	Have you attached the proof of authorisation to sign on behalf of the bidder in the Technical Bid?	
12.	Have your Technical Bid been prepared and attached as per the requirements of the Tender?	
FINANCIAL BID		
13.	Have you studied carefully the departmental estimate?	

Bill of Quantities

Name of the Work: Supply & Installation of Push Back Chairs in the Main & Mini Auditoriums at Science City, Kolkata.

Sl.No	Description	Unit	Quantity	Rate	Amount
1	Supply, Fitting and Fixing of Push Back chairs as per the specifications, design and drawings to be fixed in rows as per site condition and numbered suitably after carefully removing the existing chairs (Rates must be inclusive of all taxes,duties, transportation at site including loading, unloading, stacking, etc. all complete)	Each	1060.00	6,300.00	6,678,000.00
	Functional Specification: Push Back chair with a simultaneous movement of seat & back, with a auto stop at all places and lateral movement of the back and an inclined movement of seat.				
	Technical Specification:				
	a) Back: Frame made of MS Tube of 19mm X 19mm X1.6 mm, Size - 470mmX600mm. Back foam size 480mmX710mm with 150mm foam thickness at lower side, 90mm at mid-section, 110mm at top side with a foam density of 50±5%				
	b) Seat: 15mm P.P moulded inner seat frame of size 480mmX490mmX15mm. ● Seat foam size: 530mmX480mmX150mm at front side & 110mm at back side with a density of 50±5%				
	c) Push back mechanism:				
	● A metal sheet mechanism duly embossed of size 450mmX440mmX1.6mm				
	● Block to be 2 triangular blocks duly embossed - 300mmX300mm with 4 of 9mm holes.				
	● Longitudinal tubes of 1.6mm thickness, size 40mmX20mmX490mm - with 2 tubes each and 4 longitudinal tubes of size 20mmX6mm duly bent in shape to shape Riveted/Welded & approximately 350 mm long.				
	● Seat Back Bracket Interconnected/ Riveted/ Welded and Back Bracket to be 200mmX60mmX1.6mm.				
	● Seat Back Bracket to have stopper cup with 5 rivets and approximately 170mmX340mmX1.5mm - 2 pairs for Seat/Back.				
	● All rivets to be with nylon washers and pneumatic machine only.				
	● Rollers to withstand temperatures up to 200° and of sizes - 22 mm width & 38 mm Dia, duly riveted and welded supported by metal sheet of size 30mmX120mm - 1 pair.				
	● All stopper material to be reinforced by nylon tubes of size 30mm.				
	● Metal stand to be 300mmX300mmX3mm duly bent in 1 piece supported by 3 structures 20mmX40mmX270mm each.				

Sl.No	Description	Unit	Quantity	Rate	Amount
	d) Side Panels: All side panels to be of 12mm Plywood covered with fabric and fused with foam, side panel to cover all metal parts.				
	e) Fabric: FR coated fabric passing FR test BS EN 1021:1 or BS 5852 Part 1, (Smouldering Cigarette test) can be provided.				
	f) Small Cup holders: 460mmX100mmX40mm duly ribbed and supported by 12mm plywood 350mmX70mm cushioned and upholstered.				
	g) Installation: For installation, chairs are bolted to the ground using chemical fasteners of Hiliti or any other similar brand to be approved.				
	●5/16X1 INCH (4 Nos) for back mounting with 5/16 washer				
	●6mmX25mm (4 Nos) for seat mounting with 6mm washer.				
	●1/4X1.5 INCH (4 Nos) for armrest mounting.				
	●1/4X1.5 INCH (8 Nos) for mechanism mounting on stand. (For 21 INCH/535mm CTC).				
	●10mmX95mm of chemical fasner for stands mounting on ground.				
	Estimated amount			Rs	6,678,000.00

● **Special Notes:**

Polyurethane Foam					
No.	Property	Unit	Specification		Test Method
			Seat	Back	
1	Apparent Density(Core Density)	kg/m ³	50±5	48±5	ISO 845 - 1988
2	IFD @ 25%	kg/314 cm ²	15-18	11 14	ISO 2349-1997
3	IFD @ 40%	Kg/315 cm ²	21-24	17-20	ISO 2349-1997
4	Tensile strength	Kg/cm ²	>1.1mm	1.0mm	ISO 1798-1997
5	Tear strength	Kg/cm ²	>0.5mm	>0.5mm	ISO 8067-1989

●

Certifications: ISO-9001, ISO-14001, OHSAS-18001, Green Guard Certified and BIFMA compliant

Special Terms & conditions

NOTE :

- 1 Tenderers should visit the site before quoting the rate to understand the nature of work and condition of the site.
- 2 Rate shall be quoted inclusive of all materials, labour, duties, wastage of materials etc. required for this job & **excluding GST(Percentage of applicable GST along with HSN code must be specified clearly for both the items separately)**. No additional payment shall be made by the Science City for this purpose.
- 3 The works shall be required to be carried out without obstructing the visitor's/ audience movements and may also be required to carry out beyond office hours/day & night for which no additional payment shall be made.
- 4 Time is the essence of this order. Fabrication, Supply and installation of the ordered items shall be made at Science City, Kolkata strictly as per enclosed drawing and specifications within the stipulated time as mentioned in the letter of intent.
- 5 Bad workmanship will not be accepted and if carried out is liable to be rejected and should be rectified by the successful tenderer at his own cost.
- 6 All materials must be approved by the Engineer-in- Charge before supplying at site.
- 7 Rates shall be quoted inclusive of all minor civil repairing / mending of the surface good.
- 8 If any defect arises within warranty period, it should be attended within two days and replace the defectives during the warranty period. An undertaking letter should be submitted along with the bill in this regards.
- 9 Regarding the work the directives of the Engineer-in-Charge shall be final and binding.

Approved make of Materials:

- 1 **Teak Wood:** Only seasoned and knot/ crack free C.P. Teak wood to be used.
- 2 **Ply Wood:** Only new & latest stock of first grade Phenol bonded plywood of Green ply (Green Marine)/ Century(Club prime) make conforming IS:710, BWP grade to be used.

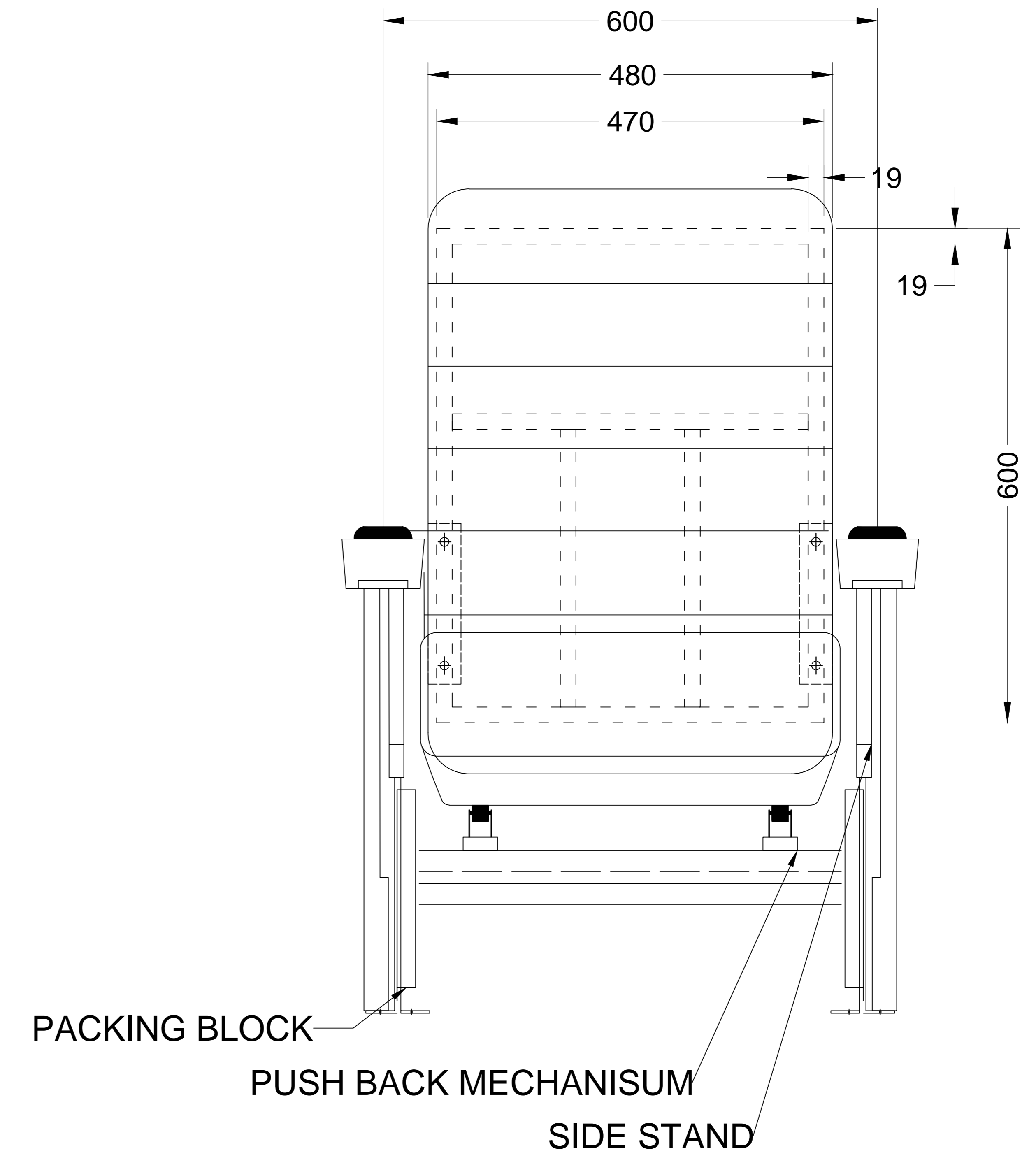
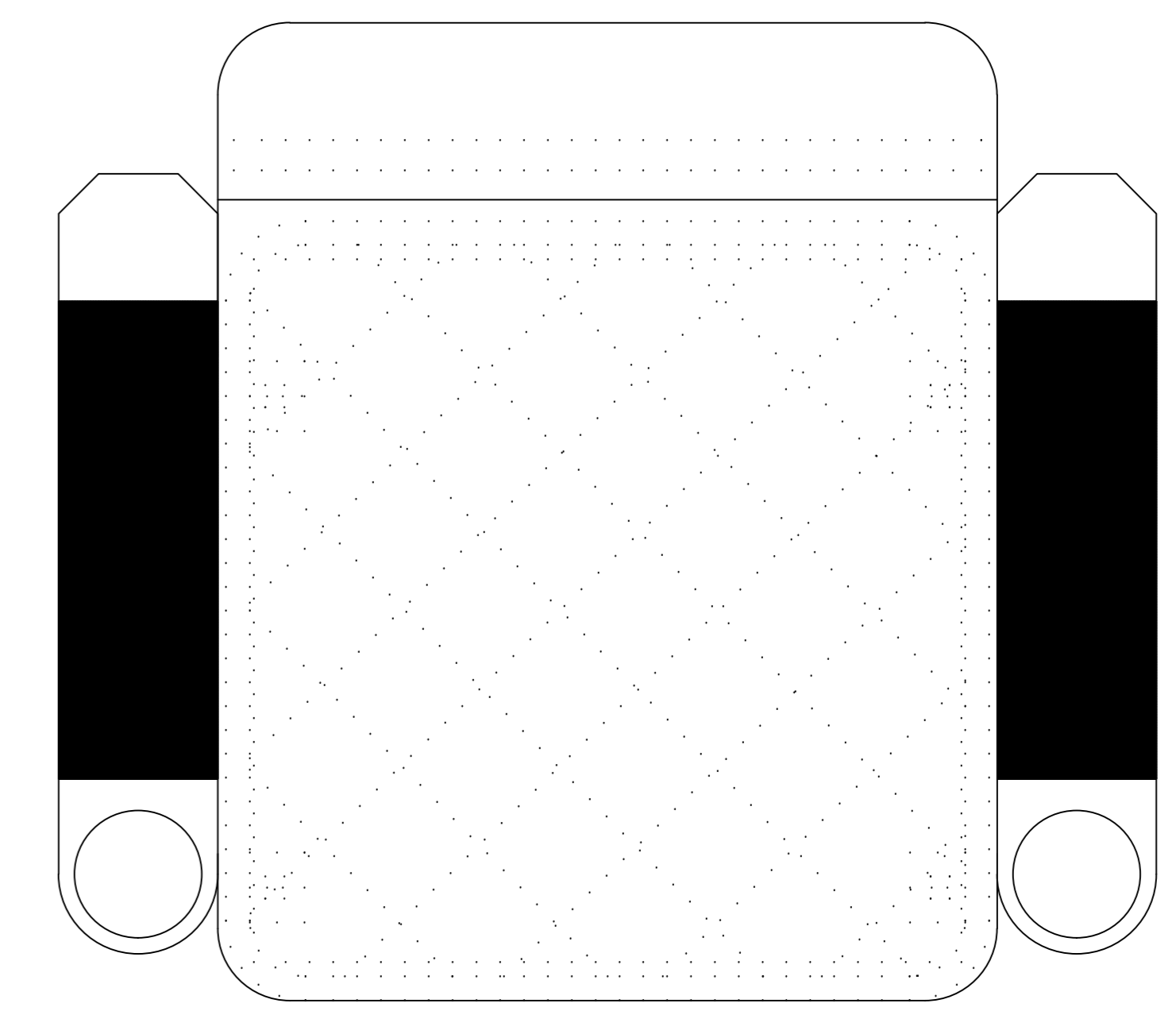
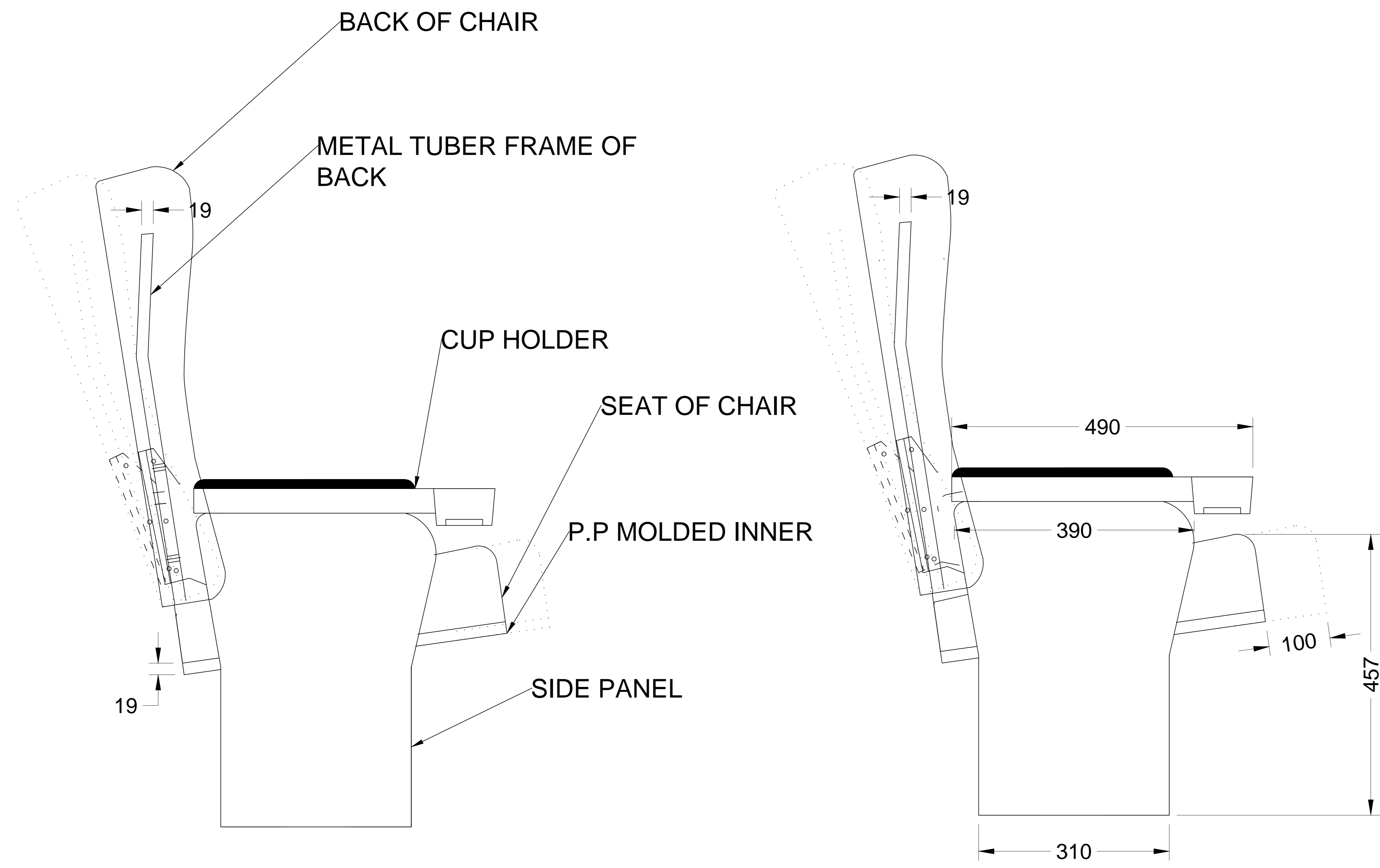

NOTE : 1. VARIATION IN DIMENSION AT TIME OF PRODUCTION +/- 4% - 8% SHOULD BE ACCEPTABLE
 2. All Dimensions are in mm and may vary as per actual site conditions.

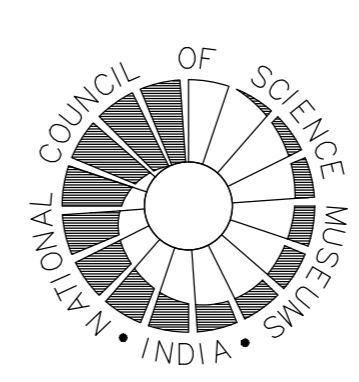
 <p style="text-align: center;">SCIENCE CITY (NATIONAL COUNCIL OF SCIENCE MUSEUMS) J.B.S. HALDANE AVENUE KOLKATA - 700046</p>			
DRAWN :	14.05.2019	CHECKED :	DATE 14.05.2019
REVIEWED :		SCALE	
APPROVED :		REF. JOB NO. 1 Off 1	
TITLE :	AUDITORIUM PUSH BACK CHAIR		DWG. NO.

SIDE PANEL DRAWING

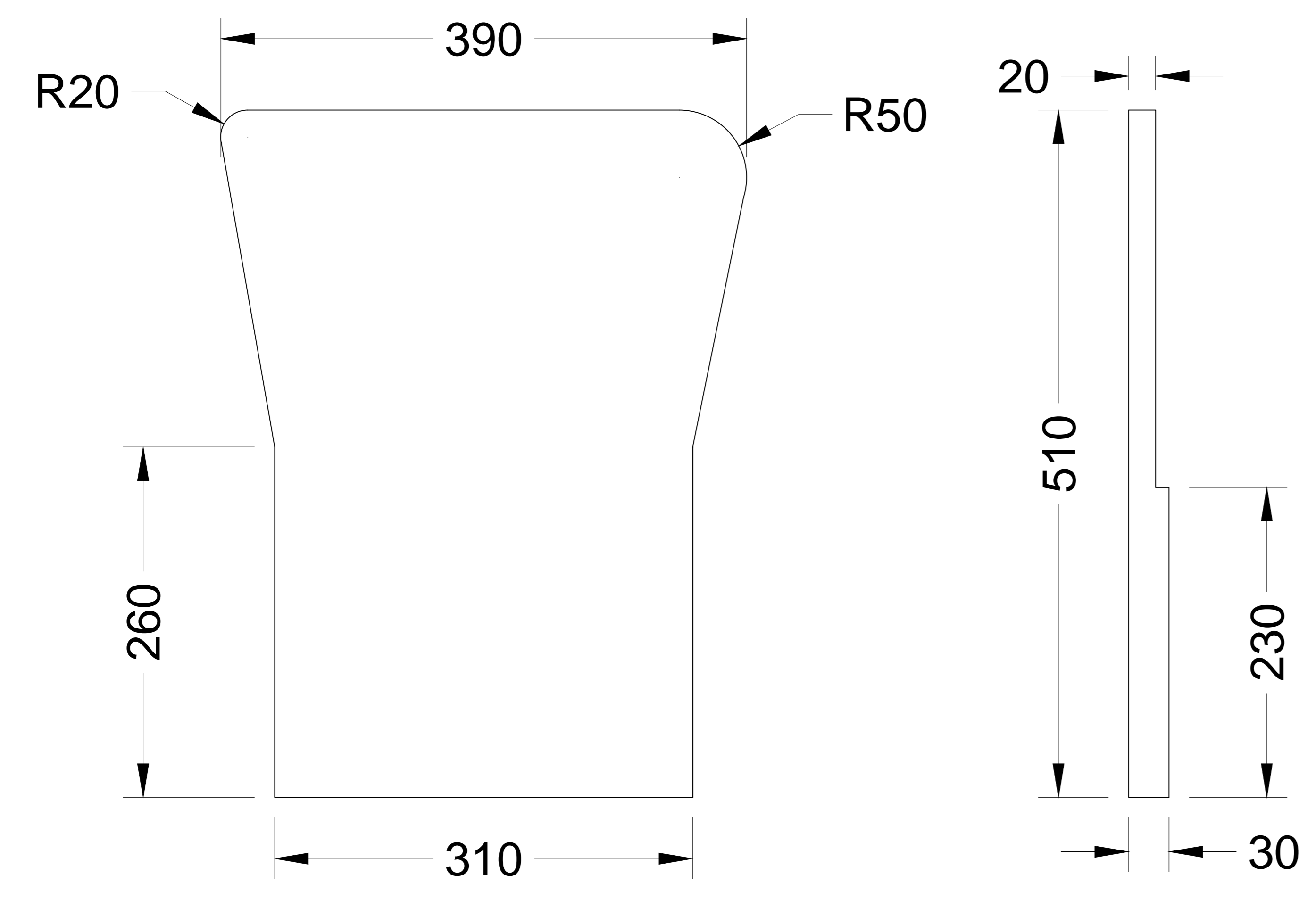

'SIDE PANEL' SIDE VIEW

'SIDE PANEL' FRONT VIEW

ARM REST DRAWING

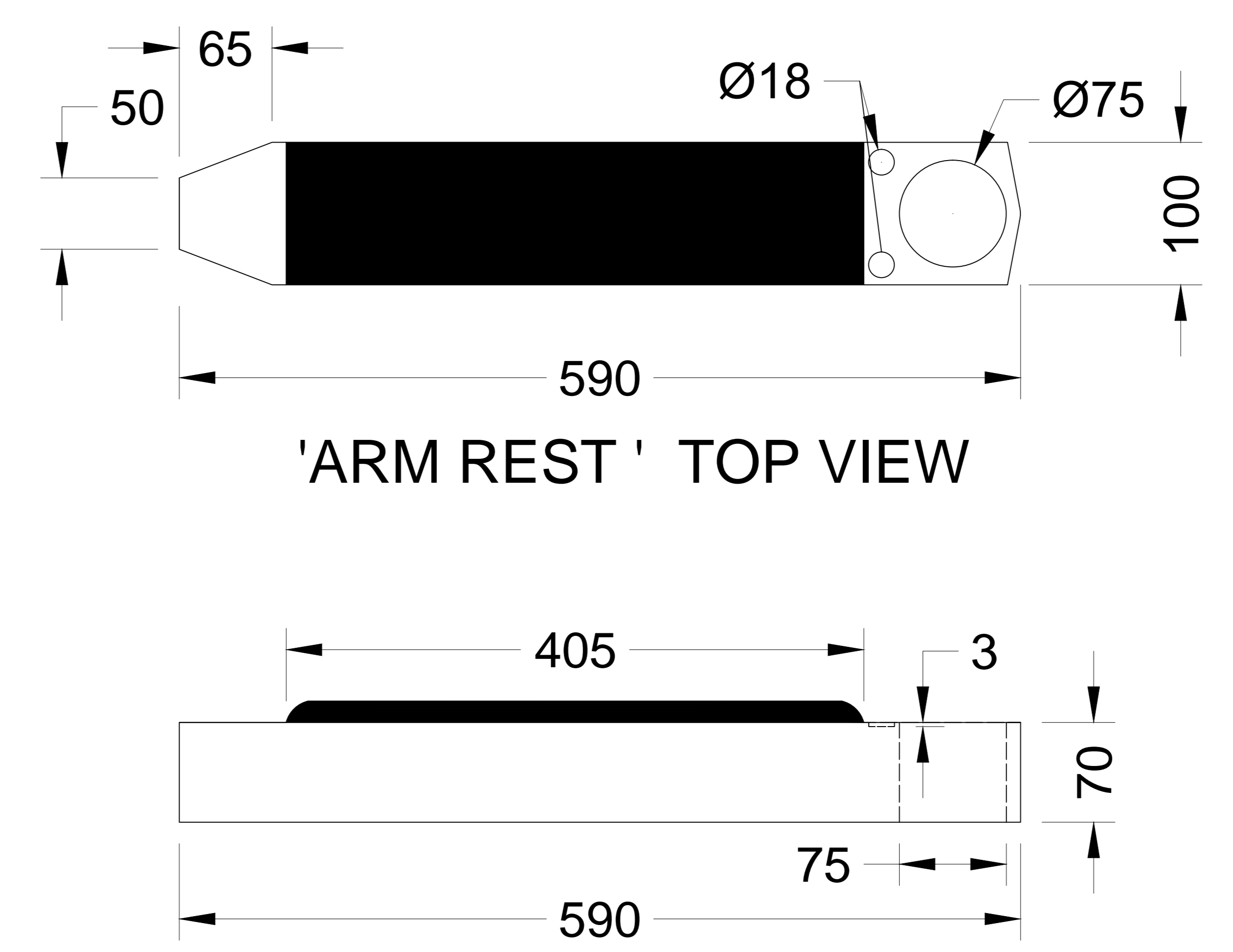

'ARM REST' TOP VIEW

'ARM REST' SIDE VIEW

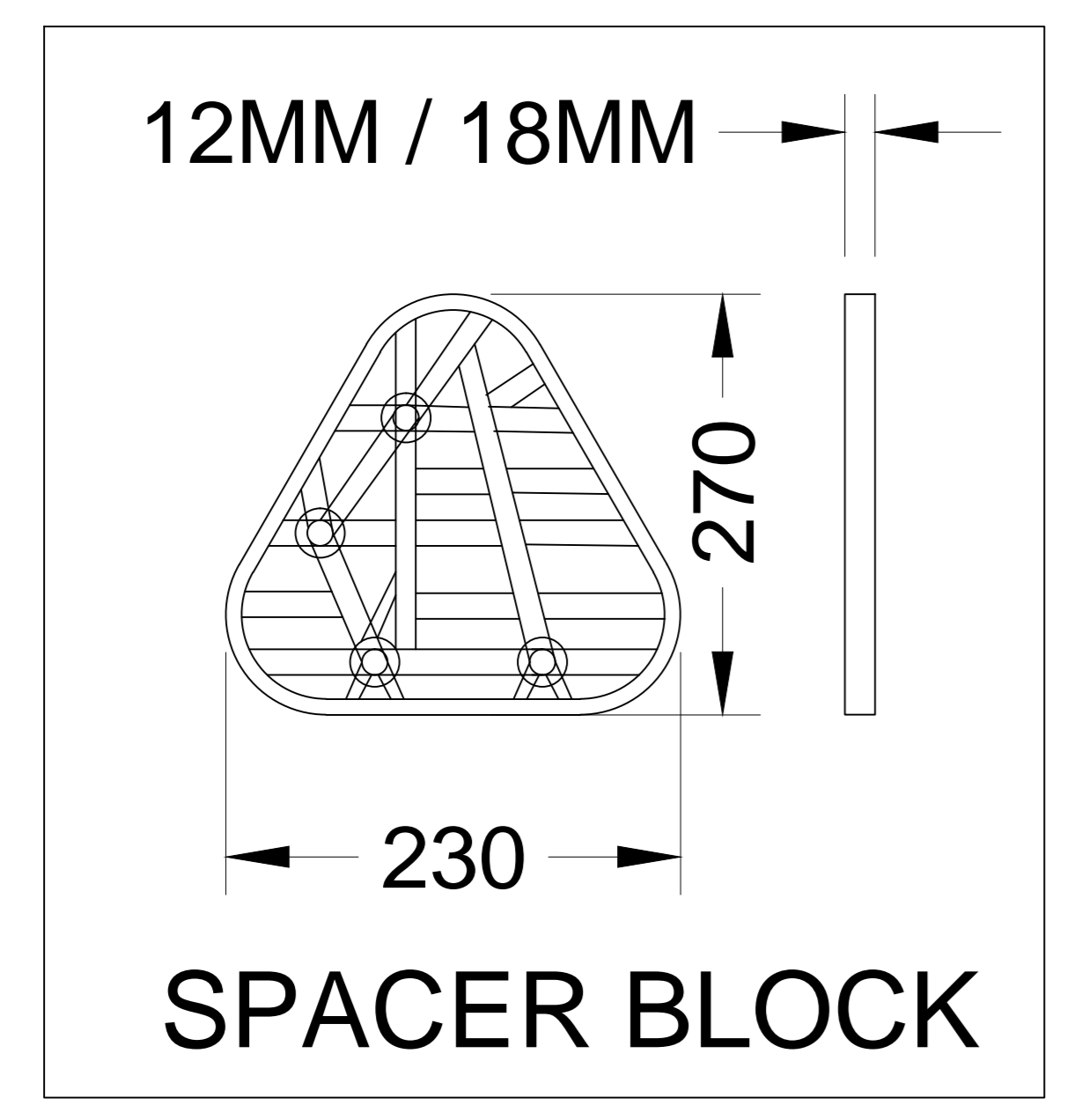

SPACER BLOCK

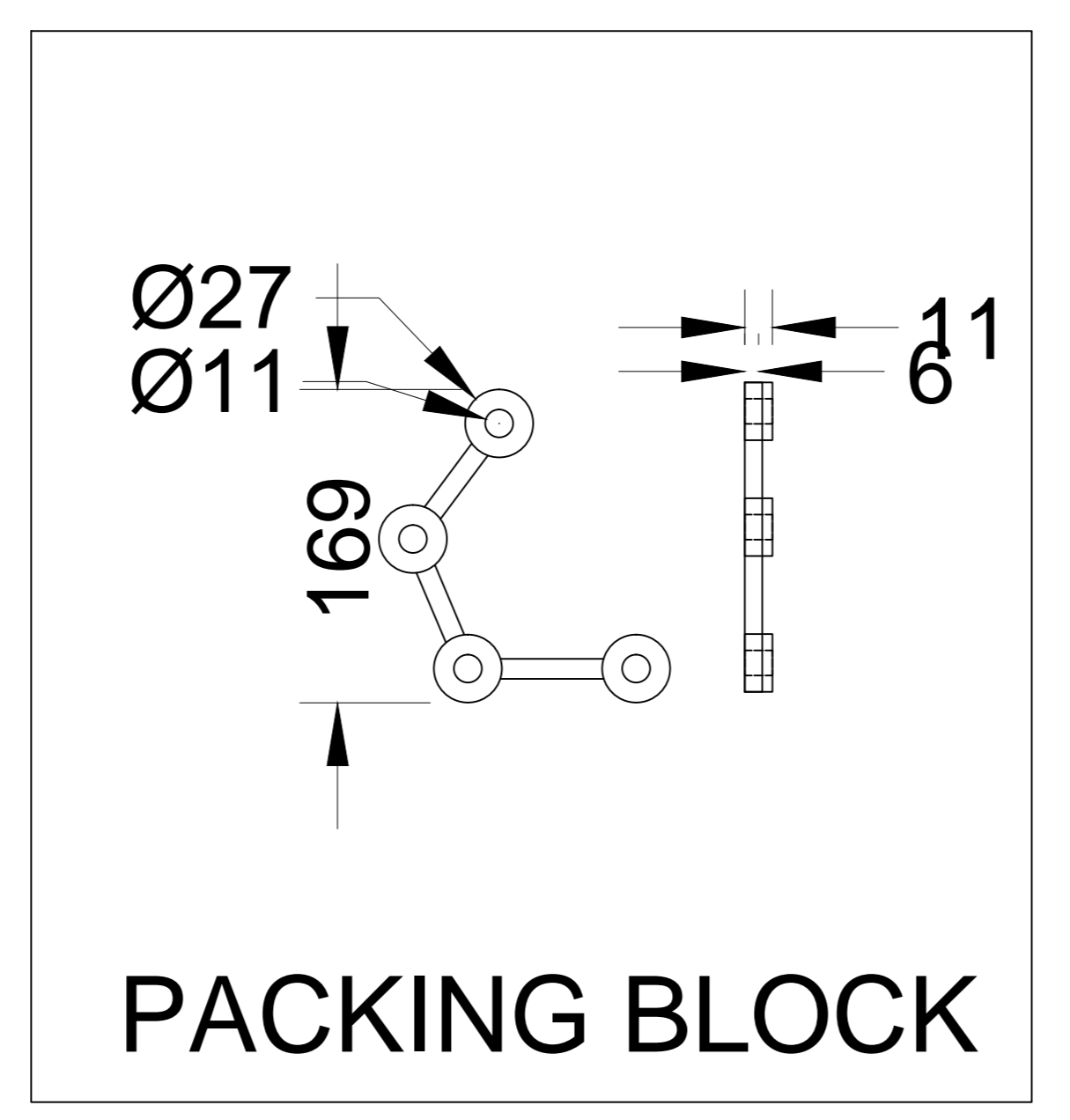

PACKING BLOCK

NOTES:-

1. All Dimensions are in mm and may vary as per actual site conditions.

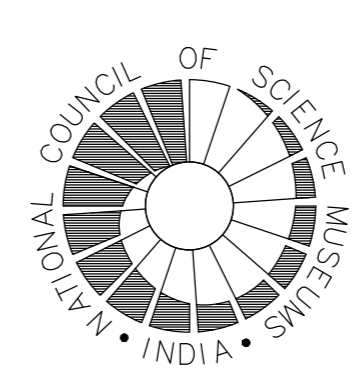
 <p>SCIENCE CITY (NATIONAL COUNCIL OF SCIENCE MUSEUMS) J.B.S. HALDANE AVENUE KOLKATA - 700046</p>			
DRAWN :	14.05.2019	CHECKED :	DATE 14.05.2019
REVIEWED :		SCALE	
APPROVED :		REF. JOB NO. 1 Off 2	
TITLE :	AUDITORIUM PUSH BACK CHAIR		DWG. NO.

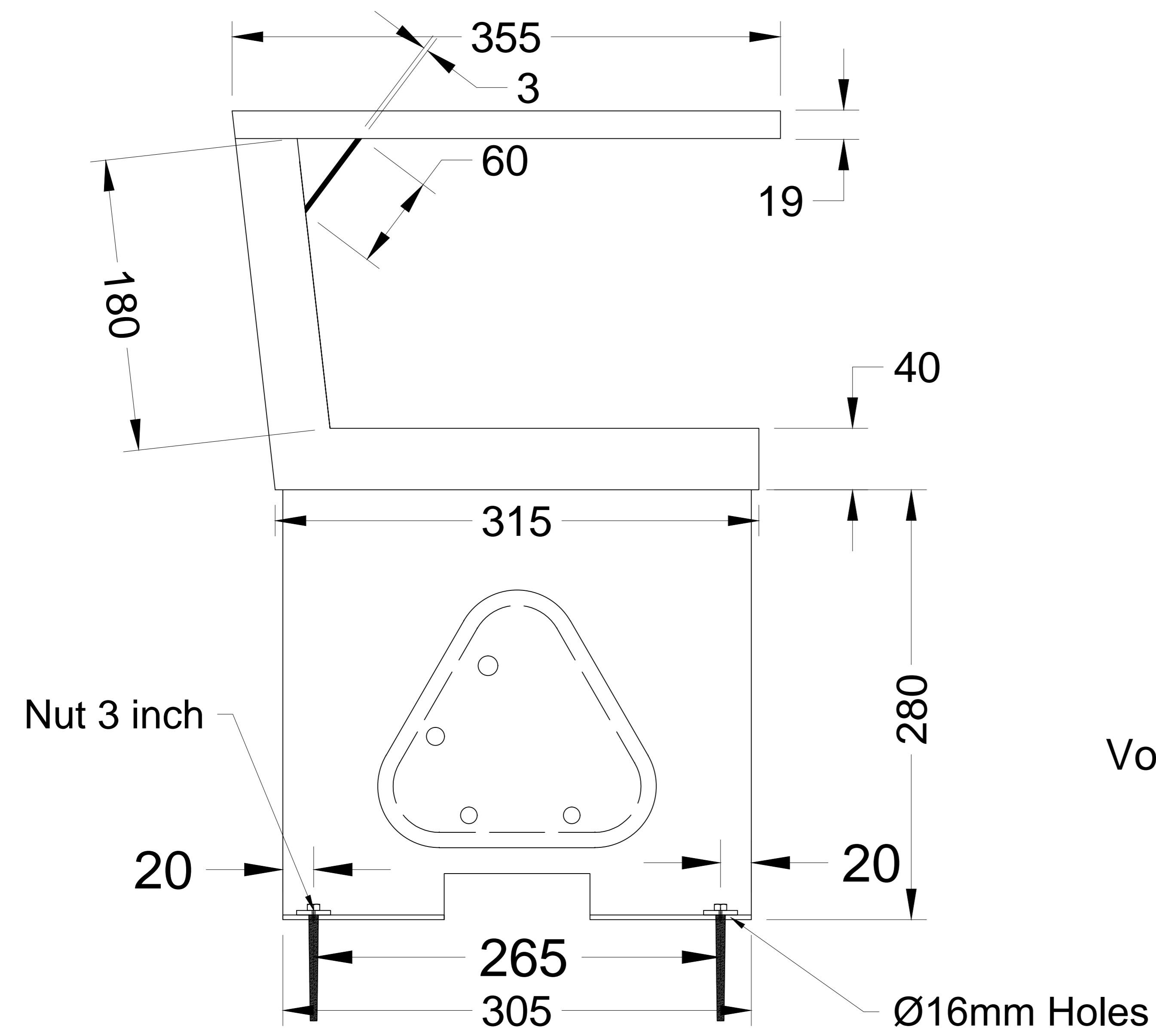

'STAND' SIDE VIEW

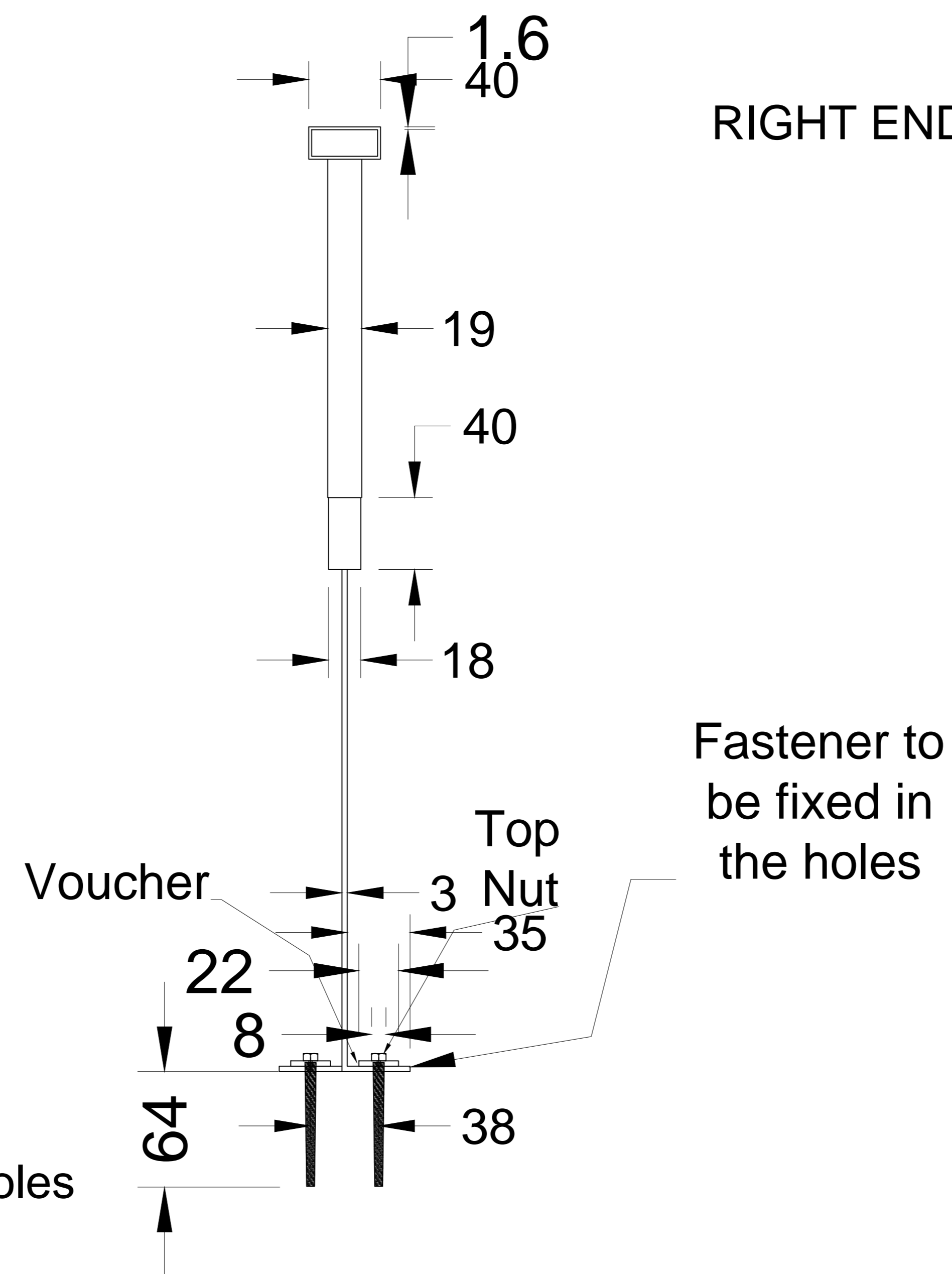

'STAND' FRONT VIEW

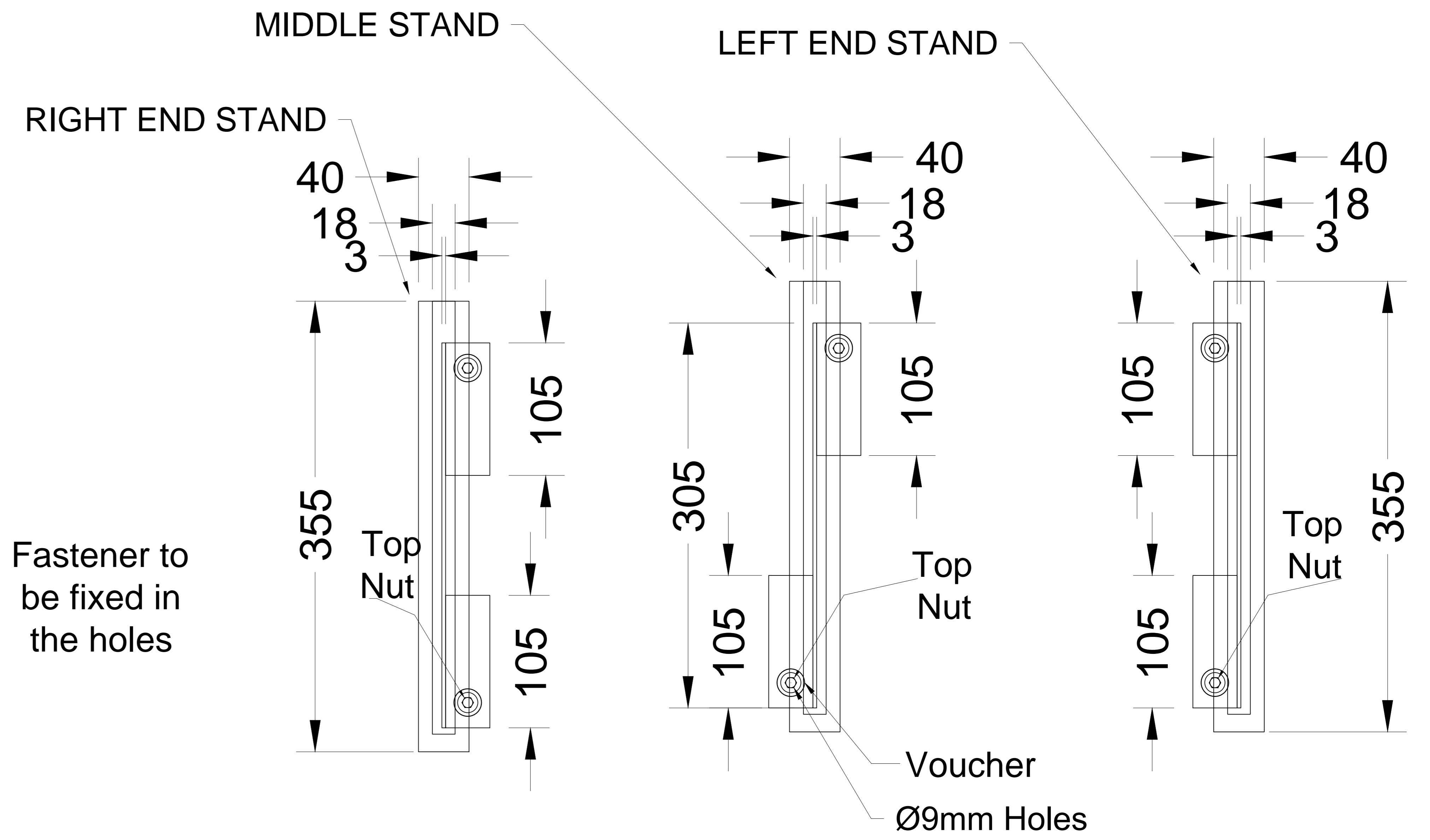

'STAND' TOP VIEW

STAND DRAWING

NOTES:-

1. All Dimensions are in mm and may vary as per actual site conditions.

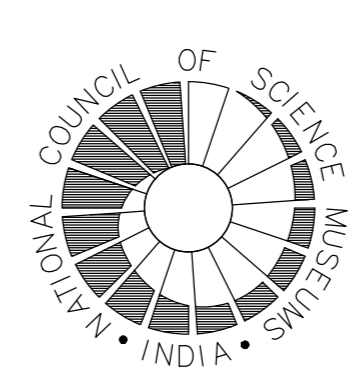
 <p>SCIENCE CITY (NATIONAL COUNCIL OF SCIENCE MUSEUMS) J.B.S. HALDANE AVENUE KOLKATA - 700046</p>			
DRAWN :	14.05.2019	CHECKED :	DATE 14.05.2019
REVIEWED :		SCALE	
APPROVED :		REF. JOB NO. 1 Off 3	
TITLE :			DWG. NO.
AUDITORIUM PUSH BACK CHAIR			

DRG. NO.

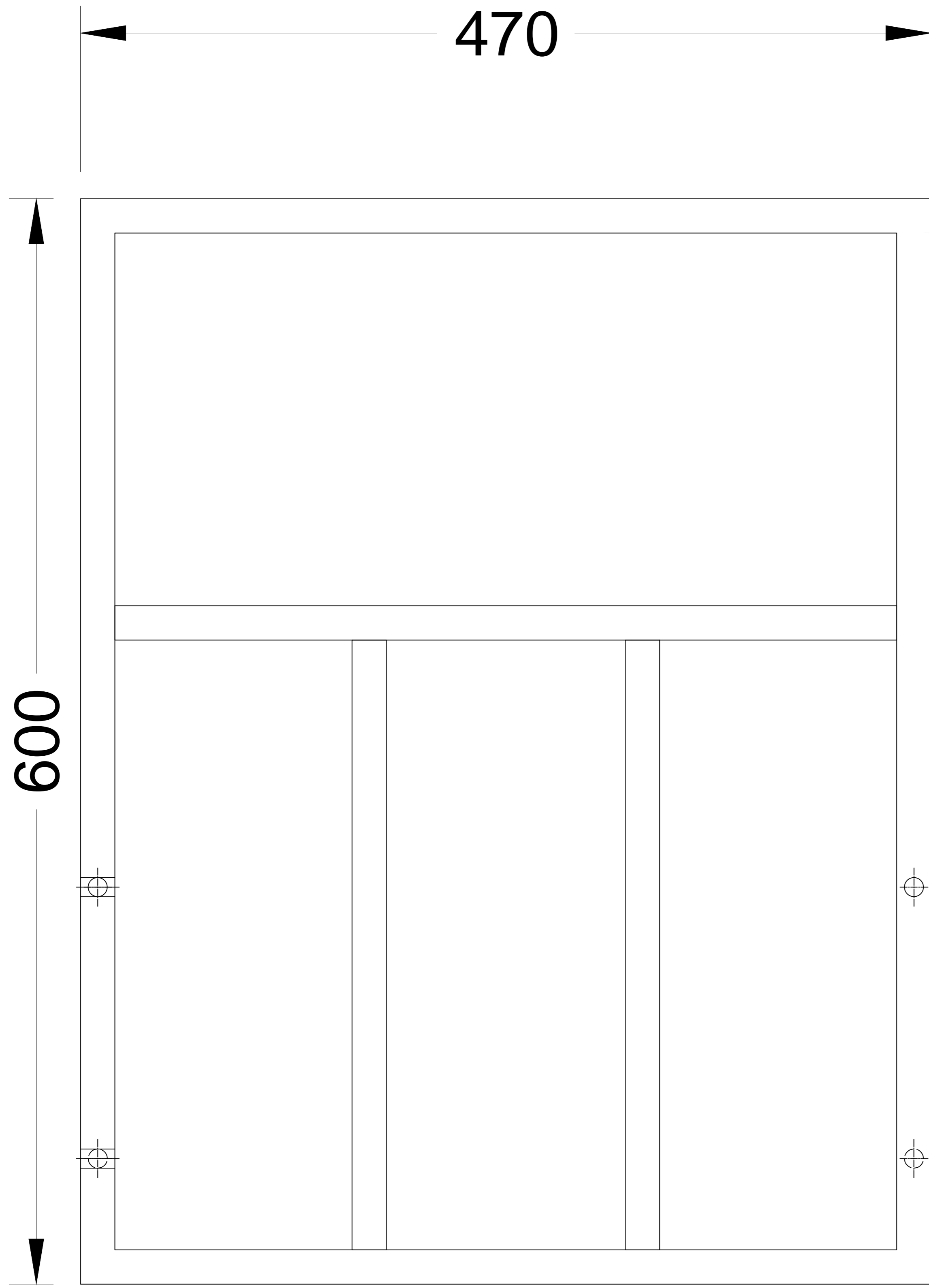

METAL TUBE BACK FRAME

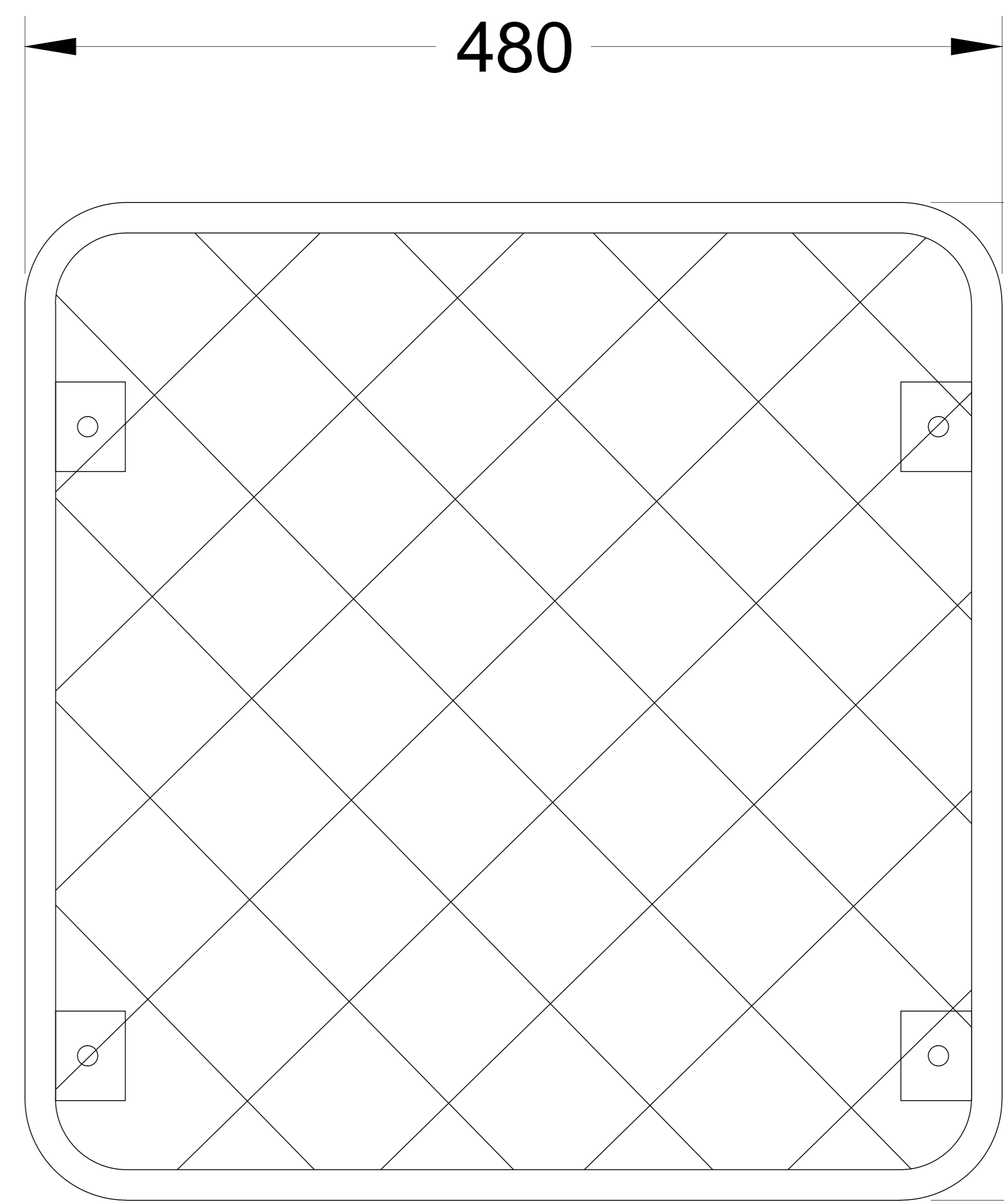
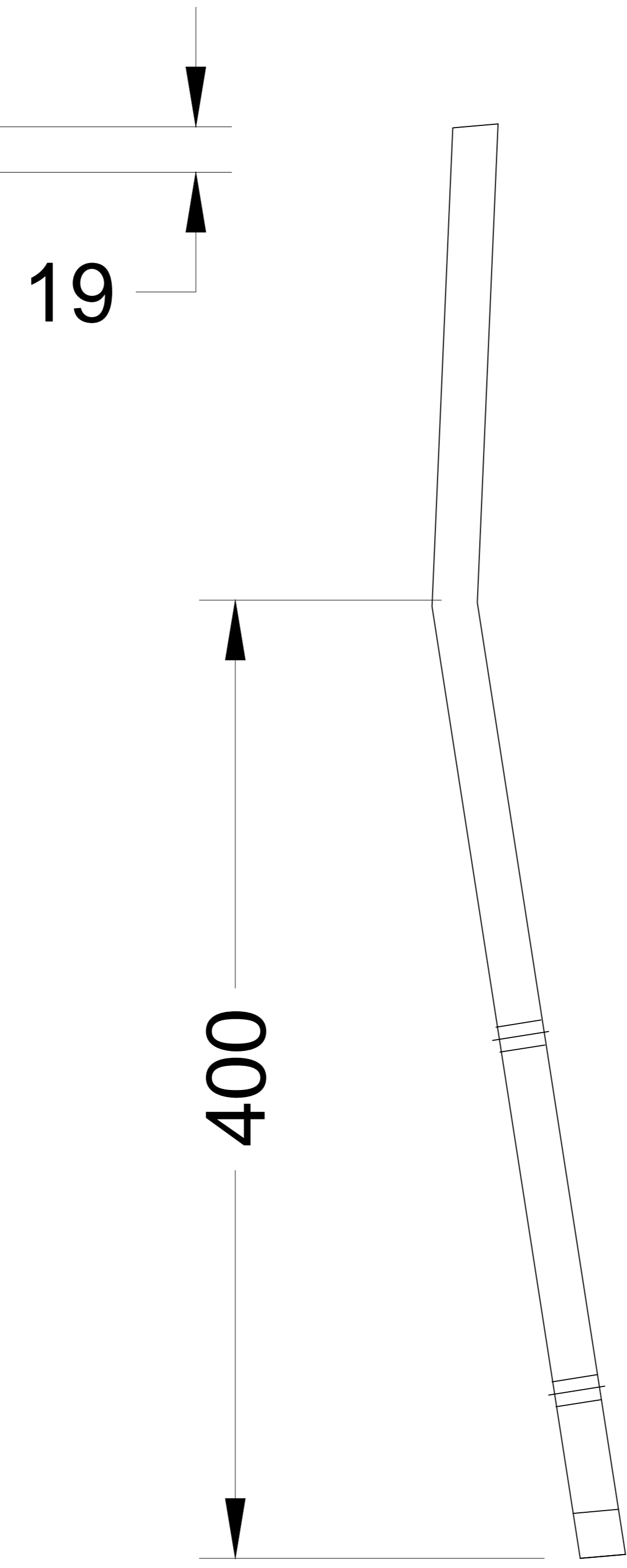

P.P MOULDED INNER

NOTES:-

1. All Dimensions are in mm and may vary as per actual site conditions.

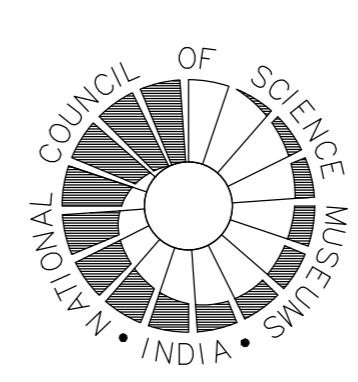
 <p>SCIENCE CITY (NATIONAL COUNCIL OF SCIENCE MUSEUMS) J.B.S. HALDANE AVENUE KOLKATA - 700046</p>			
DRAWN :	14.05.2019	CHECKED :	DATE 14.05.2019
REVIEWED :		SCALE	
APPROVED :		REF. JOB NO. 1 Off 4	
TITLE :	AUDITORIUM PUSH BACK CHAIR		DWG. NO.

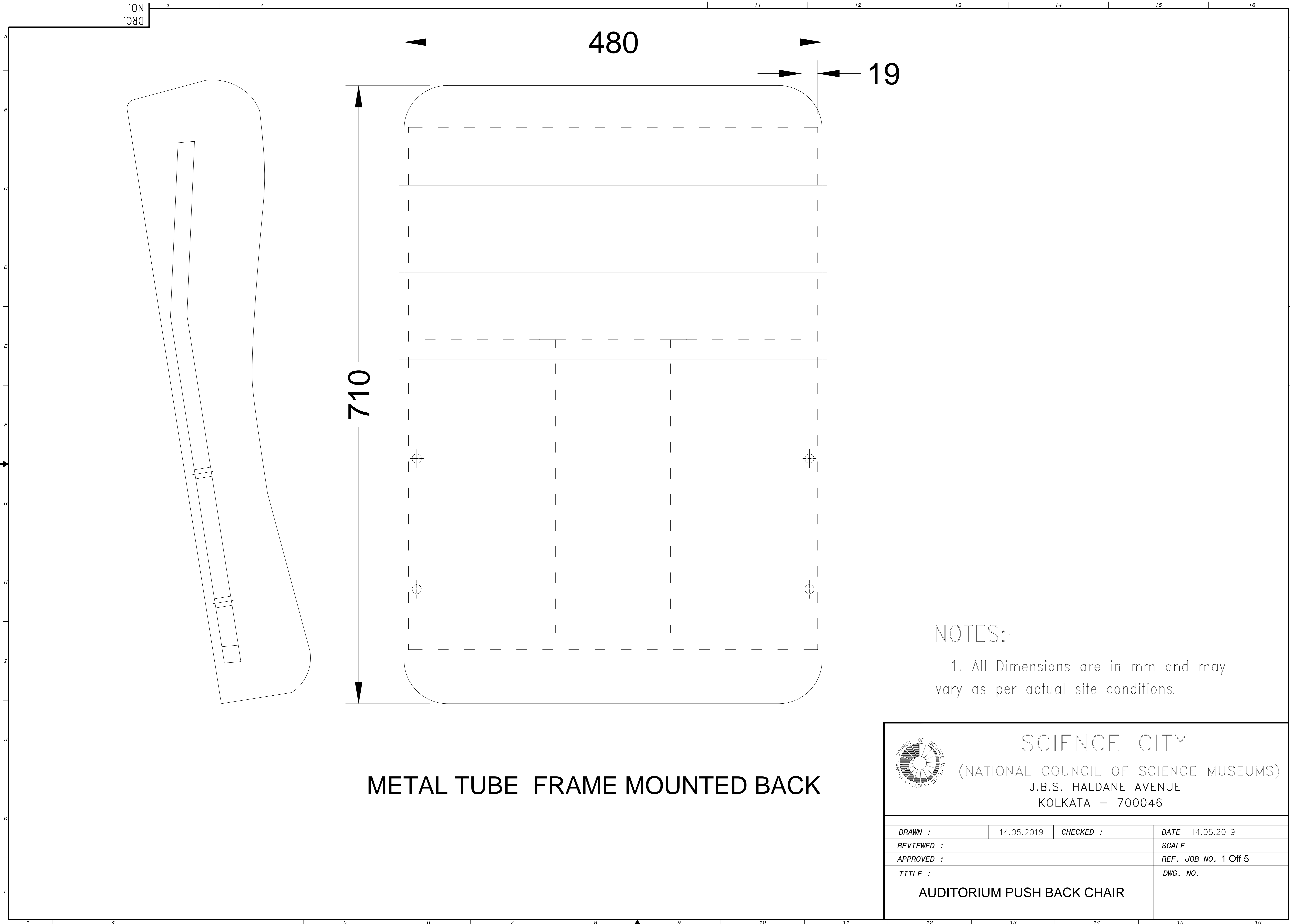

710

480

19

METAL TUBE FRAME MOUNTED BACK

NOTES:-

1. All Dimensions are in mm and may vary as per actual site conditions.

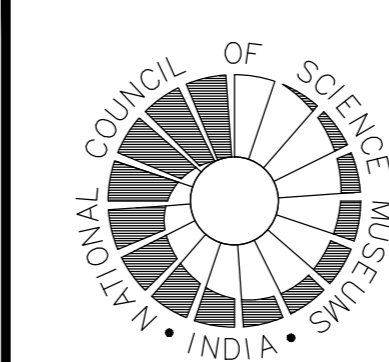

SCIENCE CITY
 (NATIONAL COUNCIL OF SCIENCE MUSEUMS)
 J.B.S. HALDANE AVENUE
 KOLKATA - 700046

DRAWN :	14.05.2019	CHECKED :	DATE 14.05.2019
REVIEWED :		SCALE	
APPROVED :		REF. JOB NO. 1 Off 5	
TITLE :	AUDITORIUM PUSH BACK CHAIR		DWG. NO.

BACK DRAWING

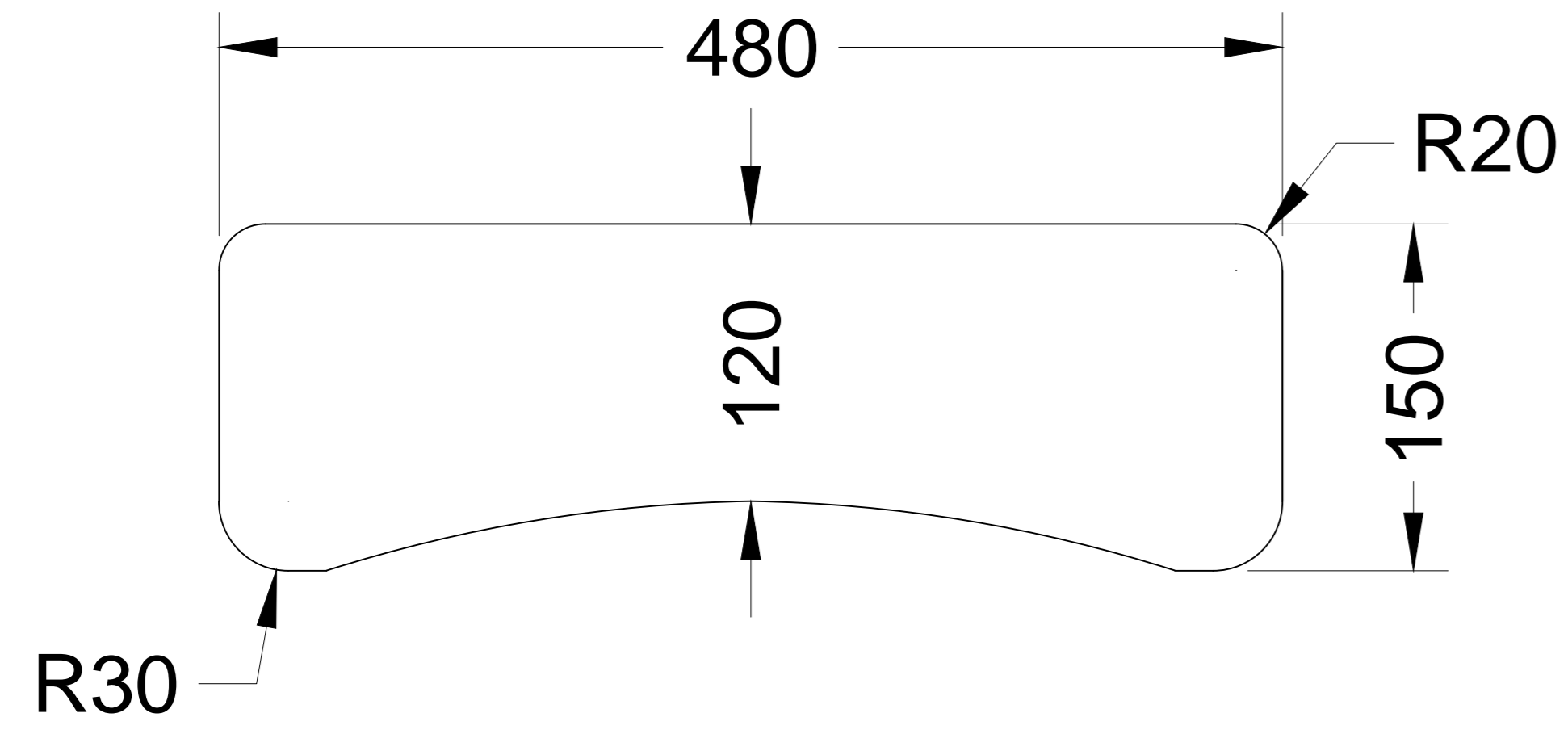

'BACK' TOP VIEW

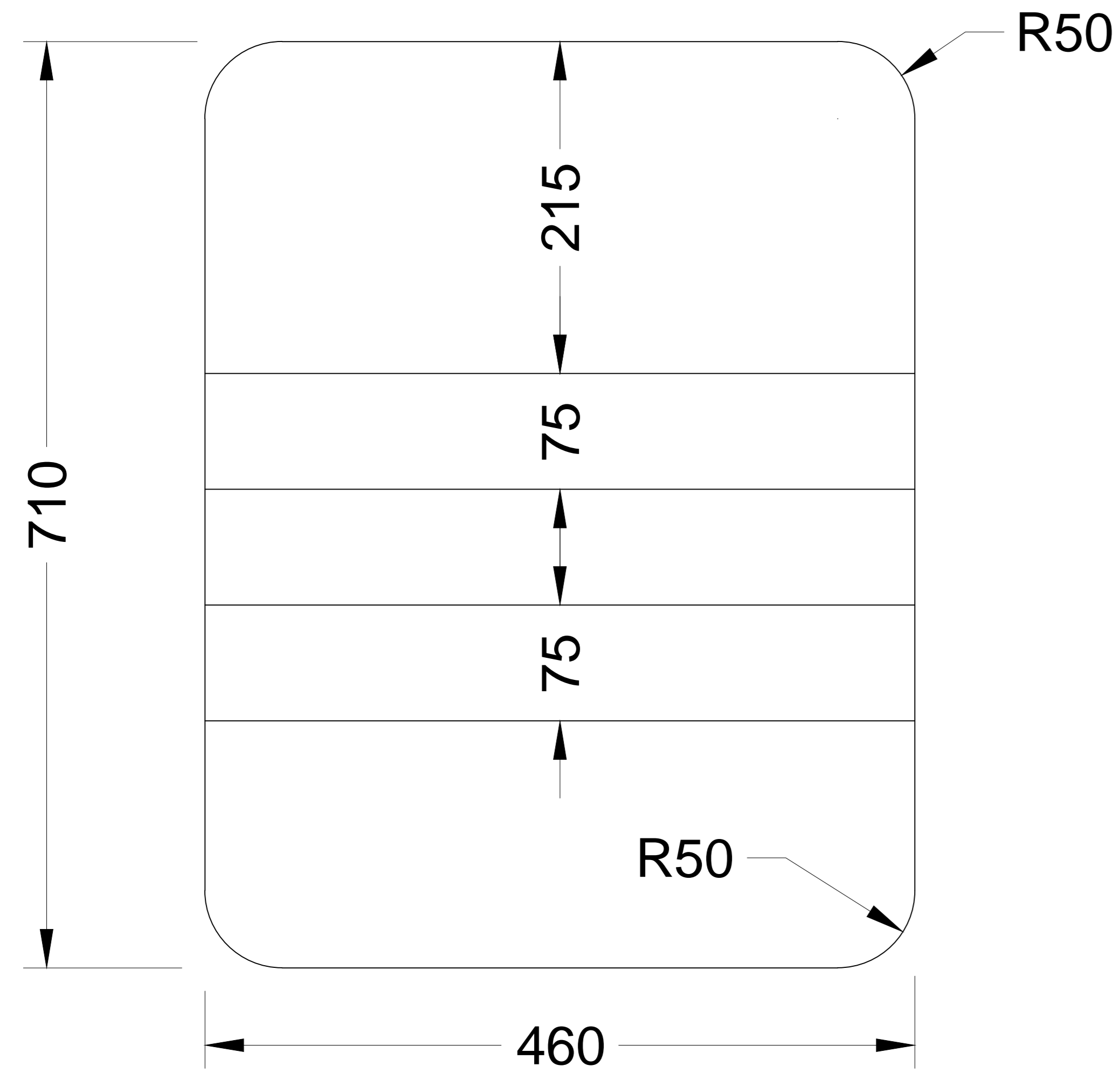

'BACK' FRONT VIEW

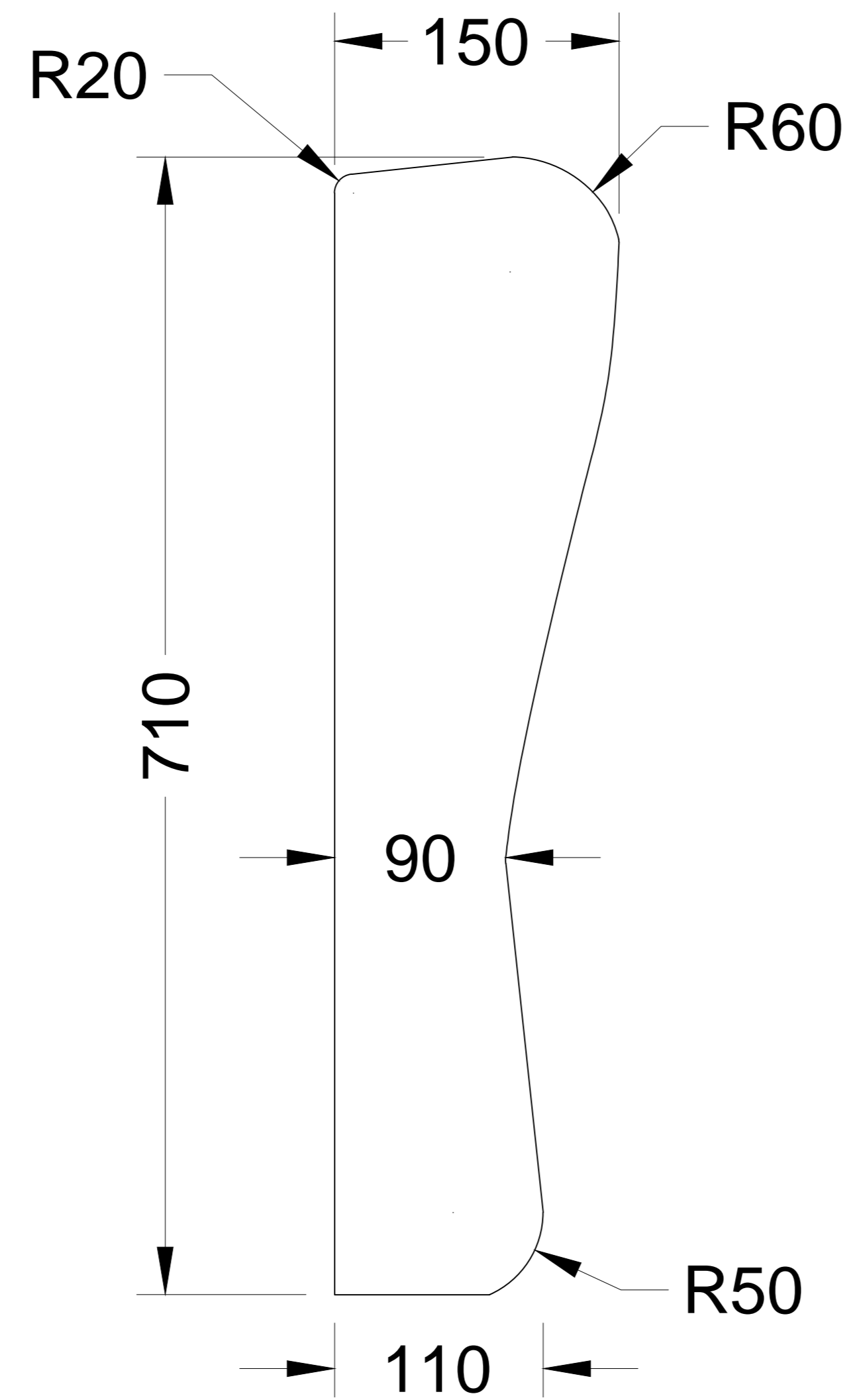

'BACK' SIDE VIEW

SEAT PAN DRAWING

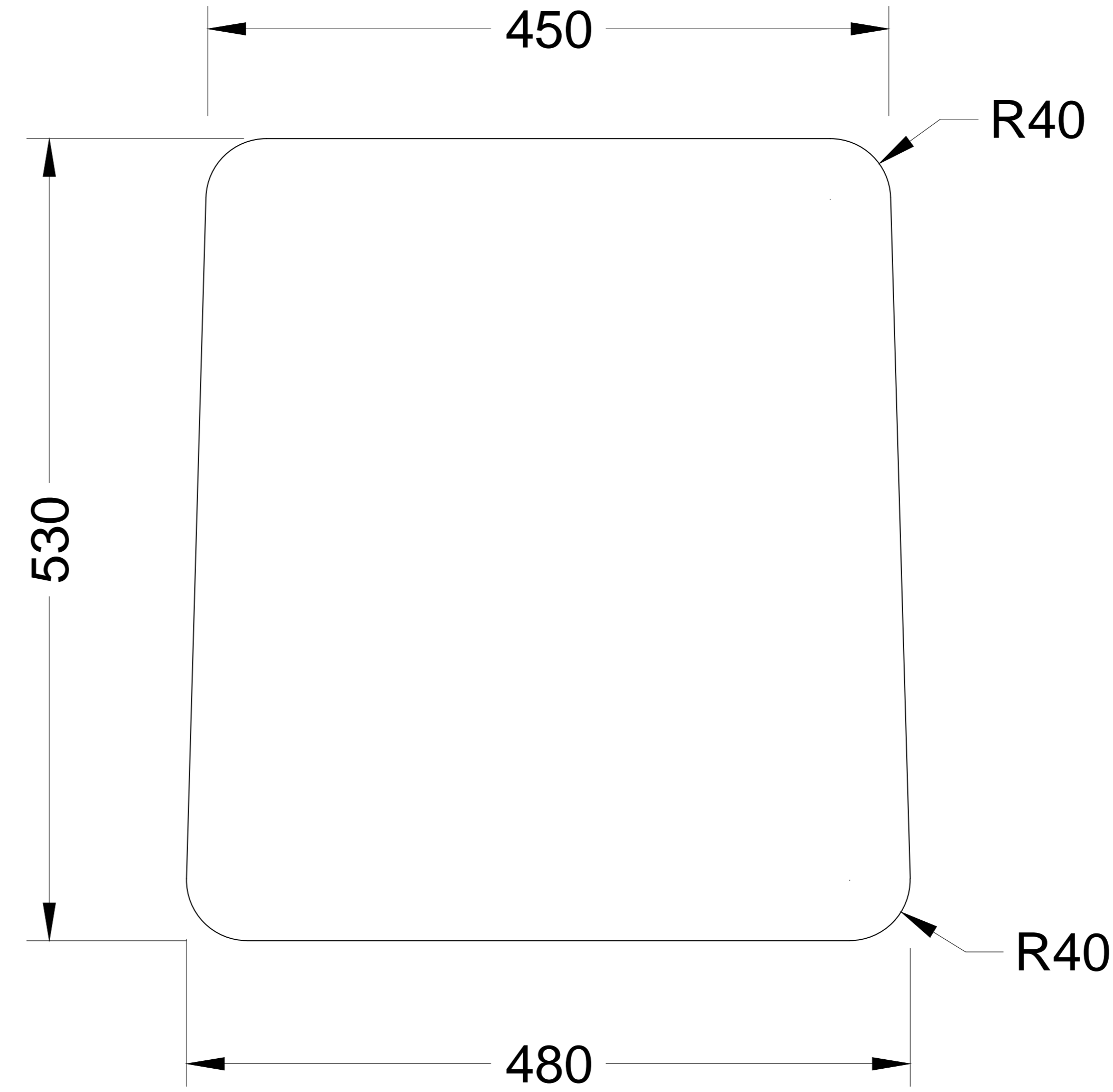

'SEAT PAN' TOP VIEW

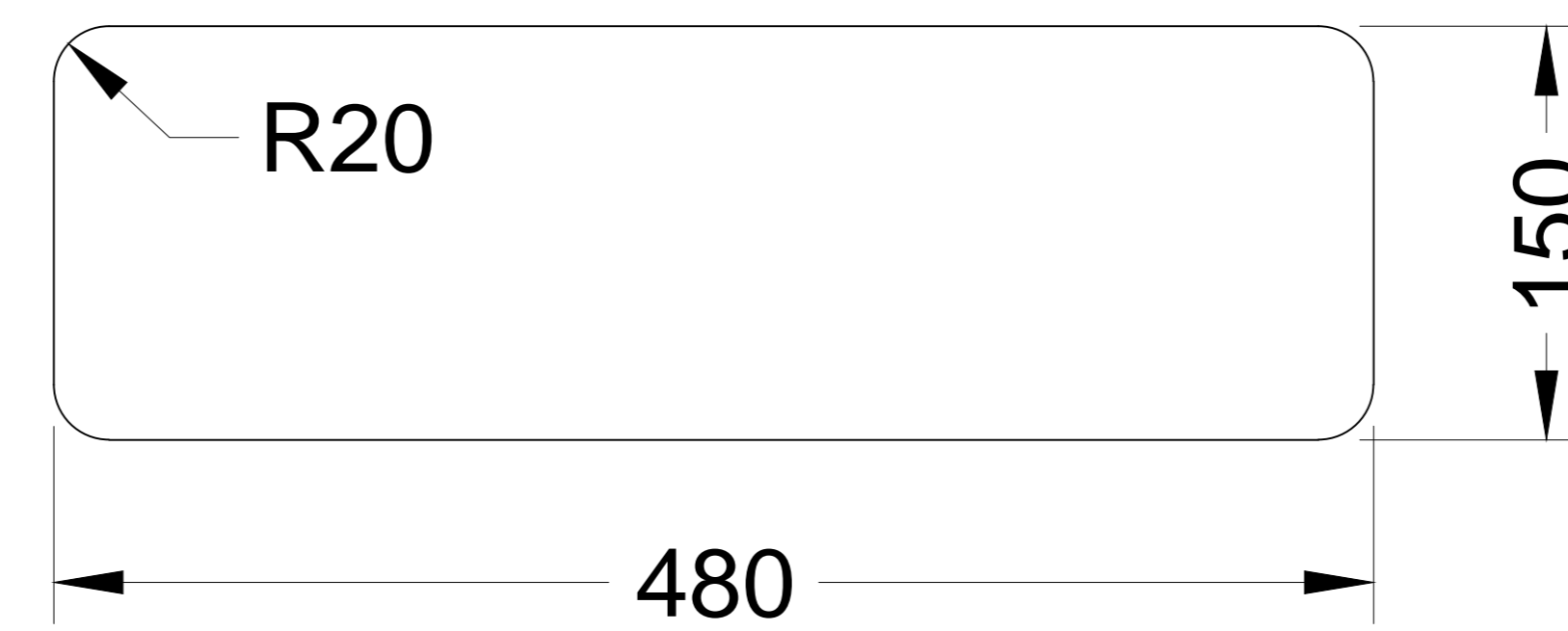

'SEAT PAN' FRONT VIEW

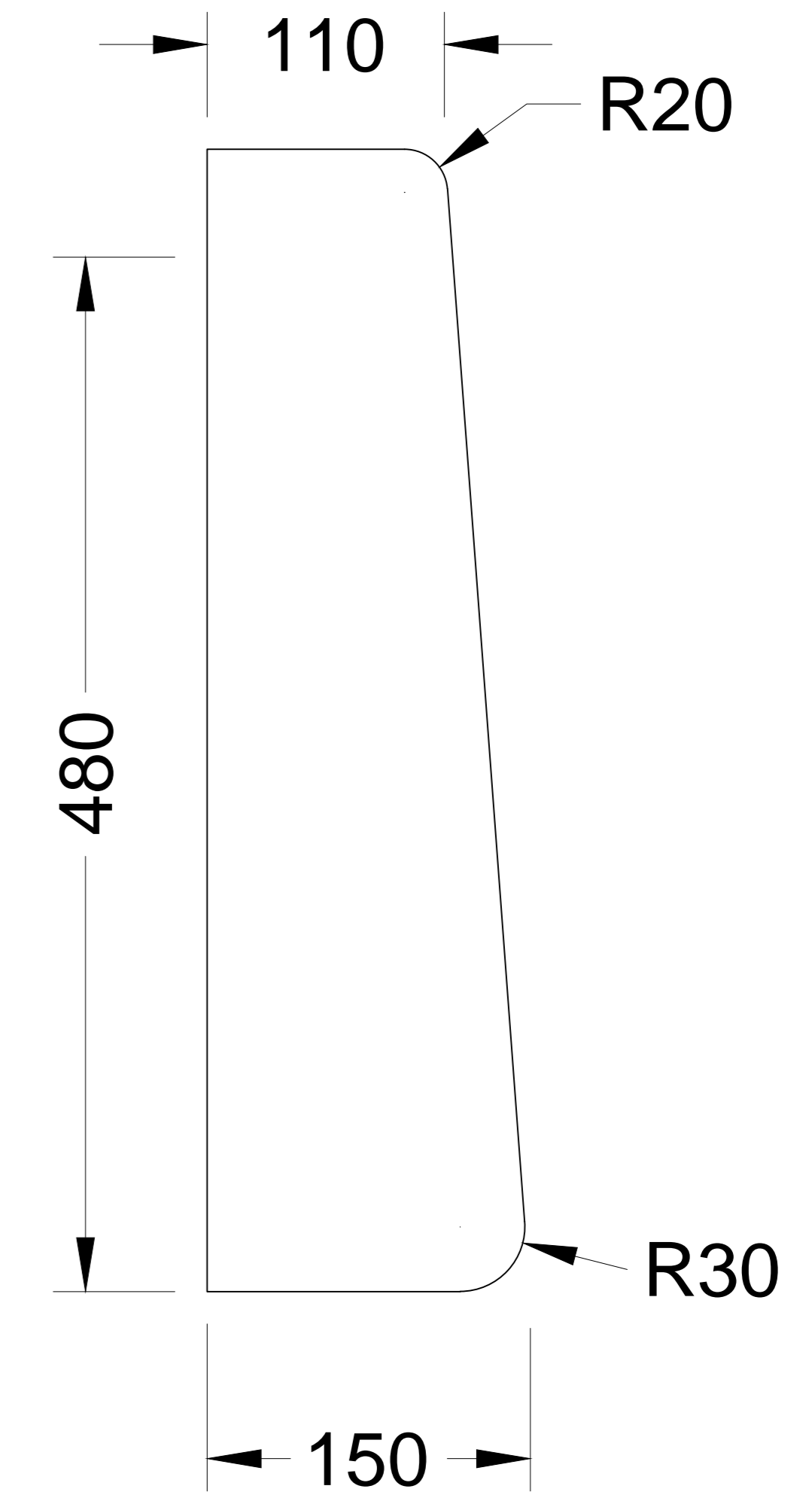

'SEAT PAN' SIDE VIEW

NOTES:-

1. All Dimensions are in mm and may vary as per actual site conditions.

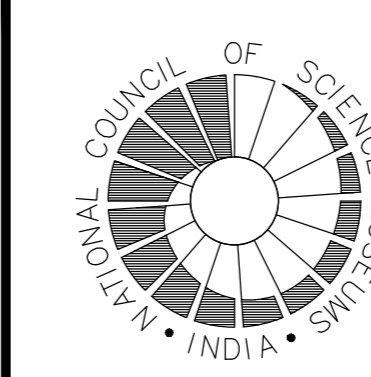

SCIENCE CITY
(NATIONAL COUNCIL OF SCIENCE MUSEUMS)
J.B.S. HALDANE AVENUE
KOLKATA - 700046

DRAWN :	14.05.2019	CHECKED :	DATE 14.05.2019
REVIEWED :			SCALE
APPROVED :			REF. JOB NO. 1 Off 6
TITLE :	AUDITORIUM PUSH BACK CHAIR		DWG. NO.

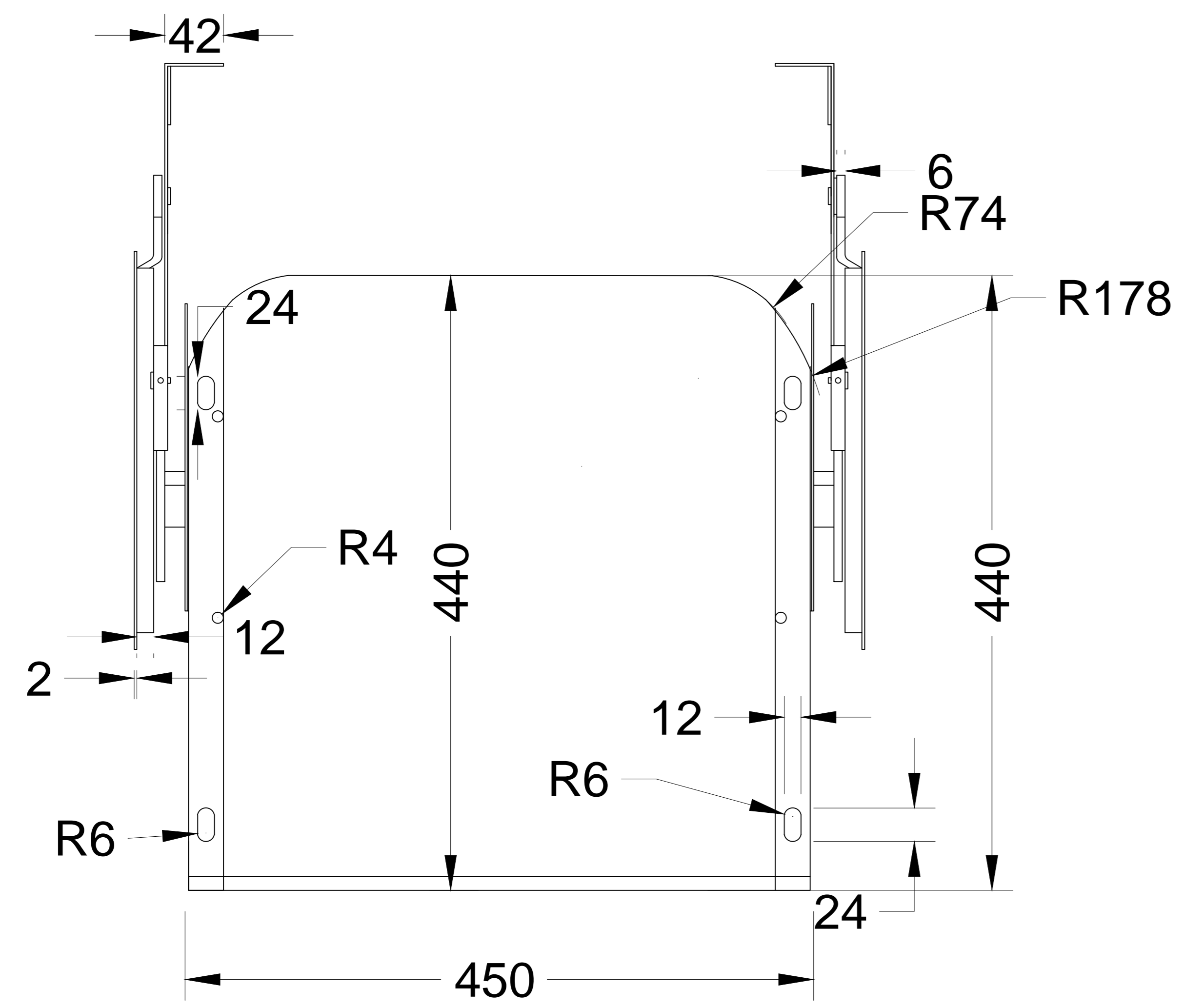

TOP VIEW

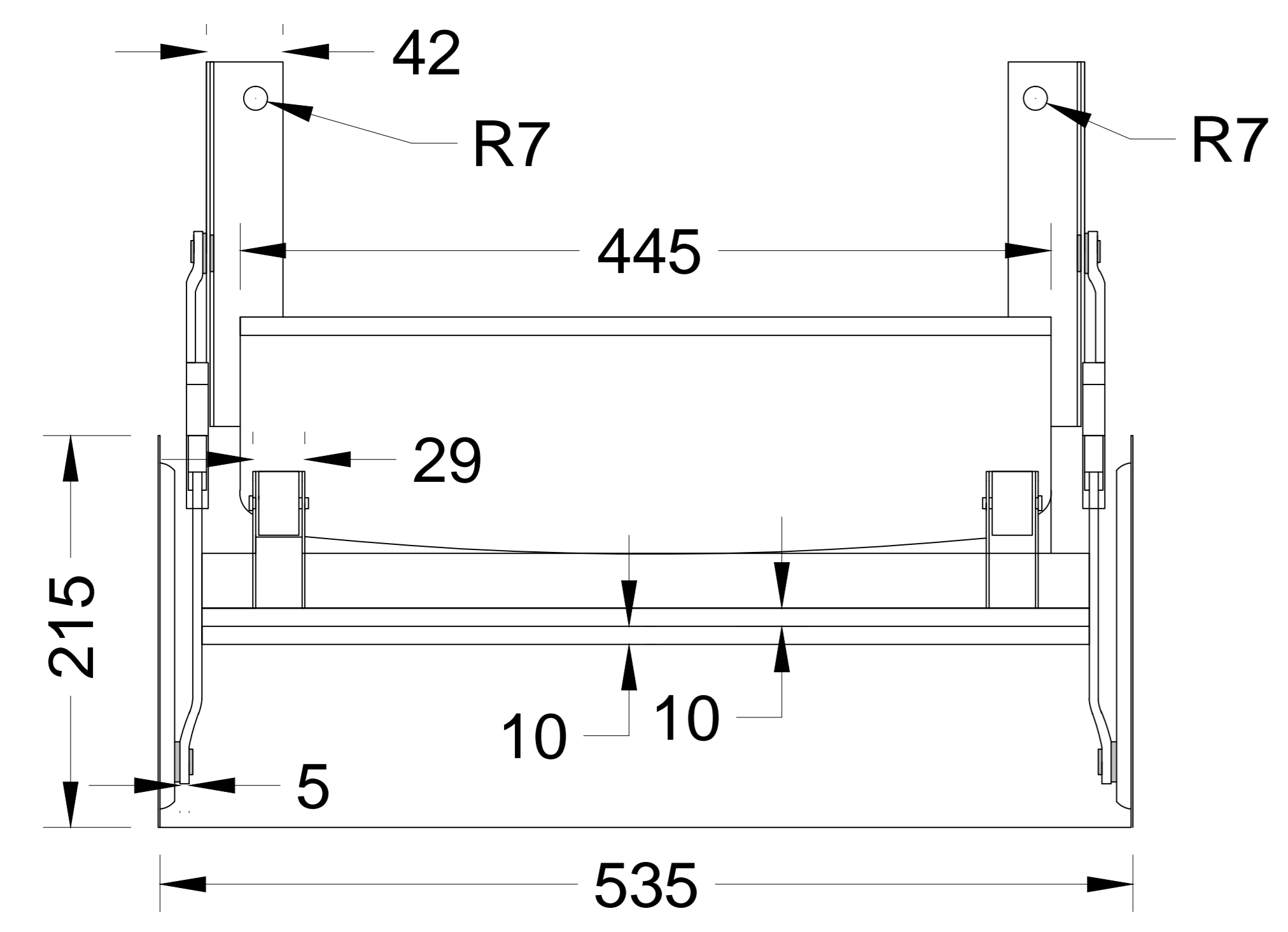

FRONT VIEW

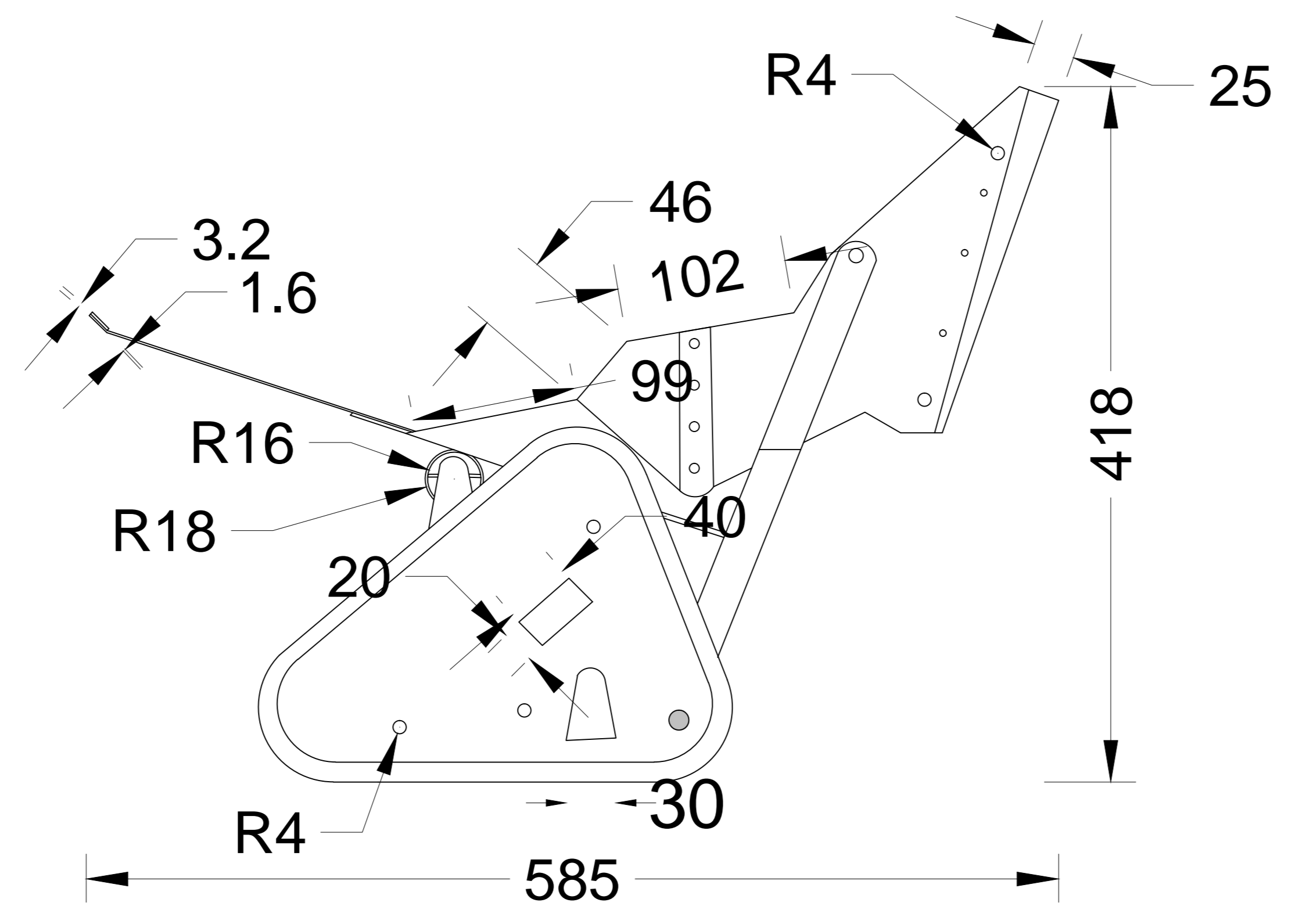

SIDE VIEW

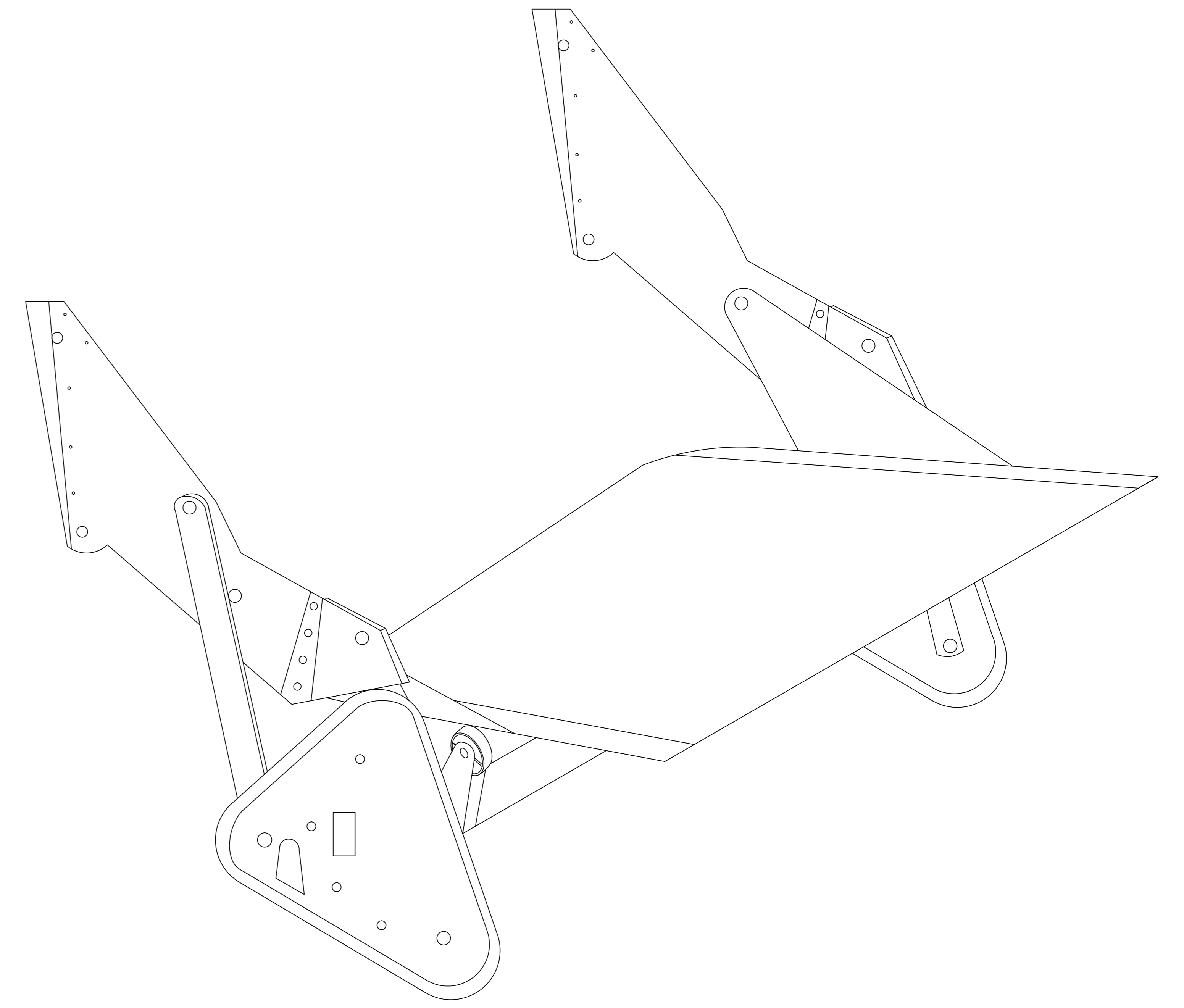

ISOMETRIC VIEW

NOTES:-

1. All Dimensions are in mm and may vary as per actual site conditions.

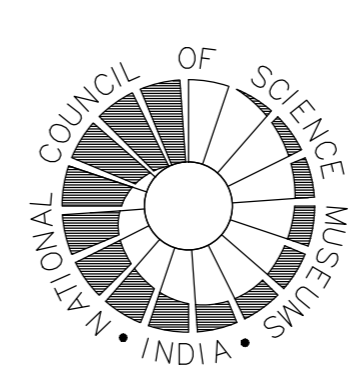
		<p>SCIENCE CITY (NATIONAL COUNCIL OF SCIENCE MUSEUMS) J.B.S. HALDANE AVENUE KOLKATA - 700046</p>	
DRAWN :	14.05.2019	CHECKED :	DATE 14.05.2019
REVIEWED :		SCALE	
APPROVED :		REF. JOB NO. 1 Off 7	
TITLE :	AUDITORIUM PUSH BACK CHAIR		DWG. NO.